

UNCLASSIFIED

AD 404 800

DEFENSE DOCUMENTATION CENTER

FOR

SCIENTIFIC AND TECHNICAL INFORMATION

CAMERON STATION, ALEXANDRIA, VIRGINIA



UNCLASSIFIED

NOTICE: When government or other drawings, specifications or other data are used for any purpose other than in connection with a definitely related government procurement operation, the U. S. Government thereby incurs no responsibility, nor any obligation whatsoever; and the fact that the Government may have formulated, furnished, or in any way supplied the said drawings, specifications, or other data is not to be regarded by implication or otherwise as in any manner licensing the holder or any other person or corporation, or conveying any rights or permission to manufacture, use or sell any patented invention that may in any way be related thereto.

404 800

404800

63 3 5

TM-1146/000 00

Augmented Satellite Control Facility

System Description

1 April 1964

TECHNICAL MEMORANDUM

(TM Series)

DDC AVAILABILITY NOTICE

Qualified requesters may obtain
copies of this report from DDC.

This document was produced by SDC in performance of contract AF 19(628)-1648, Space
Systems Division Program, for Space Systems Division, AFSC.

Augmented Satellite Control Facility
System Description

by

S. Weems

1 April 1963

Approved

R. D. Knight

SYSTEM

DEVELOPMENT

CORPORATION

2500 COLORADO AVE.

SANTA MONICA

CALIFORNIA

The views, conclusions or recommendations expressed in this document do not necessarily reflect the official views or policies of agencies of the United States Government.

Permission to quote from this document or to reproduce it, wholly or in part, should be obtained in advance from the System Development Corporation.

Although this document contains no classified information it has not been cleared for open publication by the Department of Defense. Open publication, wholly or in part, is prohibited without the prior approval of the System Development Corporation.



SUMMARY

This description of the Augmented Satellite Control Facility (SCF) is approached from two points of view: first, the equipment subsystems are described in terms of their capabilities, functions, and primary usages; second, the principal activities performed by the SCF; i.e., telemetry, tracking, commanding, and scheduling are explained in such a way that the previously described equipments are tied together into systems, with emphasis on the functional aspects of SCF operations.

The SCF is composed of a central control station called the Satellite Test Center (STC) and six remote tracking stations, three of which have limited dual capability. The STC is equipped to support six satellites simultaneously. Its data processing subsystems are divided into two main functional groupings: one, the "Bird Buffer complex," is vehicle oriented, and has eight CDC 160A computers, each of which can be individually assigned to an active satellite as a buffer; the other grouping is the off-line-computer complex, which uses four CDC 1604 computers to do the main computational chores for the system. To achieve flexibility of operation and rapid reconfiguration, computer-controlled switching units are used to interconnect the Bird Buffers with the off-line computers on one side, and with the tracking stations on the other.

The three dual tracking stations are capable of supporting certain combinations of two satellites simultaneously. Each tracking station has three main equipment groupings:

1. Antenna subsystems--these subsystems are in closest contact with the orbiting vehicles and provide the communication links between the vehicles and the ground.
2. Data Processing subsystem--this subsystem, which interfaces with the STC via data link, is made up of two CDC 160A computers and their peripheral equipment. The two computers, one for telemetry and one for tracking and commanding, process data sent to and from the STC.
3. Telemetry, Tracking, and Command subsystems--these subsystems transform telemetry, tracking, and commanding data from the Antenna subsystems into a form suitable for the Data Processing subsystem, and vice versa.

The above three equipment groupings are connected together by manual patchboards to give tracking stations a flexibility and reconfiguration capability approaching that of the STC.

The tracking, telemetry, and commanding functions are initiated by a prepass message, which is sent to the tracking station by the STC. This message

contains the satellite acquisition data for the antennas, the telemetry mode configuration, and the command data to be sent to the satellite. Upon acquisition, tracking data are sent to the STC for orbit determination, and selected telemetry data points are processed and sent to the STC in real time. Commands are initiated at the tracking station in accordance with the instructions received from the STC, and a record of all commands sent to the satellite is returned to the STC. Commands may be initiated from the STC in real time and telemetry mode changes may be made during a pass.

The functions of the STC and the tracking stations are performed in accordance with a master schedule. This schedule, prepared by a 1604 computer program called SCHOPS, with inputs from the Multi-ops personnel, takes into account the contact times of each active vehicle with each station, the priorities of each vehicle, the system resources, and other pertinent information that affects the operating schedule. These data are processed to predict conflicting demands on system facilities. The conflicts are resolved by preset priorities or by manual intervention, and a schedule is output detailing the usage of system resources. Also part of the output is a schedule tape for driving the Switch Control Computer at the STC, which causes switches to connect and disconnect the various subsystems at the times dictated by the schedule. Tracking station subsystems are connected and disconnected manually at the times specified by the schedule.

FOREWORD

A need has been recognized for a single-document source that describes the end products of the Augmentation Program in sufficient detail to be of interest to all the diverse technical groups working on the program. Such a treatise should be useful in presenting a more complete picture to those workers who are necessarily engrossed in the minutiae of their daily tasks. It should also be of value to those who have a need for a general understanding of the overall effort without becoming excessively involved in the details of the program. This document attempts to fill this need.

In preparing this document, the author has borrowed heavily from many of the sources listed in the bibliography. In many cases whole sections were lifted intact, as were drawings and charts. The document therefore reflects the efforts of many individuals.

The system described herein is the system that was planned as of shortly before the publication date of this document. In a fast-moving program of this type, changes are inevitable and the probability is high that this document will have already become obsolete in some respects before reaching the hands of the reader. It is not planned to keep this document current; rather, it is believed that its purpose will have been achieved if it conveys a general understanding of the Augmented SCF, its equipment functions, and its philosophy of operation.

TABLE OF CONTENTS

	<u>Page</u>
Summary	1
Forward	3
1.0 Introduction.....	7
2.0 SCF Equipment.....	9
2.1 STC Equipment.....	9
2.1.1 Bird Buffer Subsystems.....	10
2.1.2 CDC 1604 Computer Subsystems.....	18
2.1.3 Communication Data Select & Cross Connect Unit and Computer Select & Cross Connect Unit.....	20
2.1.4 CDC 160A Switch Control Computer.....	21
2.1.5 Master Data Control Console.....	22
2.1.6 CDC 1604 Computer.....	23
2.1.7 CDC 160A Computer.....	24
2.1.8 CDC 1615 Magnetic Tape Unit.....	25
2.1.9 CDC 166 Line Printer.....	26
2.1.10 CDC 1612 Line Printer.....	26
2.1.11 CDC 163 Magnetic Tape Unit.....	26
2.1.12 CDC 169 Auxiliary Memory Unit.....	26
2.1.13 CDC 161 Typewriter Unit.....	27
2.2 Tracking Station Equipment.....	28
2.2.1 Antenna Subsystems.....	31
2.2.1.1 Verlorst Radar.....	31
2.2.1.2 Prelort Radar.....	32
2.2.1.3 Telemetry and Data (T&D) Antenna.....	32
2.2.1.4 TLM-18 Telemetry Antenna.....	32
2.2.1.5 Disc-On-Rod (DOR) Antenna.....	34
2.2.1.6 Tri-Helix Antenna.....	34
2.2.2 Telemetry, Tracking, and Commanding Subsystems.....	35
2.2.2.1 FM/FM Ground Station.....	35
2.2.2.2 PCM Ground Station.....	36
2.2.2.3 GP-1 Ground Station.....	37
2.2.2.4 400-mc Receiving/Commanding Equipment.....	39
2.2.3 Data Processing Subsystem.....	39
2.2.3.1 Tracking and Command Computer Subsystem (T&C).....	40
2.2.3.2 Telemetry Computer Subsystem (TLM).....	42
2.2.3.3 Input/Output Buffer (IOB).....	43
2.2.3.4 Telemetry Data Processor (TDP).....	44
2.2.3.5 Command Logic Equipment (CLE).....	44
2.2.3.6 Station Operator's Console (SOC).....	46

TABLE OF CONTENTS (Cont'd)

	<u>Page</u>
2.3	Communication Equipment..... 60
2.3.1	Computer Communications Converter (CCC)..... 60
2.3.2	Modulator and Demodulator Terminal Equipment (MODEM).. 61
2.3.3	KG-13 Cryptographic Machine..... 62
2.3.4	Automatic Resynchronizing Equipment (Auto-Resync)..... 62
3.0	Tracking Functional Description..... 64
3.1	General..... 64
3.2	Prepass Message..... 64
3.3	Acquisition..... 64
3.4	Track History.... 65
4.0	Telemetry Functional Description..... 66
4.1	General..... 66
4.2	STA Telemetry Processing Outputs..... 66
4.2.1	Preflight Mode..... 66
4.2.2	Prepass Mode.... 67
4.2.3	Real Time Telemetry Processing Mode..... 67
4.3	Telemetry Modules at the STC..... 68
4.4	Data Flow at the Tracking Station..... 68
4.5	Data Flow at the STC.... 71
4.6	Telemetry Operational Program (TLMOP)..... 71
5.0	Commanding Functional Description.... 73
5.1	General.... 73
5.2	Analog Commanding--Manual Mode..... 75
5.3	Analog Commanding--Computer Automatic Mode..... 76
5.4	Digital Commanding--Manual Mode..... 77
5.5	Digital Commanding--Computer Automatic Mode..... 79
5.6	Stored-Program Commands.... 79
5.7	Real-Time Commands.... 83
5.8	Command History..... 85
6.0	Scheduling Functional Description..... 87
6.1	General..... 87
6.2	Input Processing Module..... 88
6.3	Conflict Prediction Module..... 88
6.4	Conflict Resolution Module.... 89
6.5	Resources Allocation Module.... 89
6.6	Launch Planning Module.... 90
6.7	Output Processing Module..... 90
6.8	Simulation and Data Reduction Module..... 91
6.9	Control Module..... 91
References.....	93

LIST OF ILLUSTRATIONS

<u>Figure</u>		<u>Page</u>
1	Locations of Augmented SCF Tracking Stations	8
2	STC Equipment Block Diagram	11
3	STC Control Area Layout	13
4	Typical Augmented Tracking Station Block Diagram	29
5	Augmented Tracking Stations Equipment Configurations	33
6	Station Operator's Console (SOC)	47
7	SOC--Antenna Controller Section	49
8	SOC--Command Controller Section	51
9	SOC--Shift Supervisor Section	57
10	Augmented SCF Telemetry Data Flow	69
11	Analog Pulse Modulation Scheme	74
12	Command Message Preparation--Inputs and Outputs	81
13	Transfer of Command Message from the 1604 to the Bird Buffer	82
14	Transfer of Command Message from Bird Buffer to T&C Computer at Tracking Station	84

1.0 INTRODUCTION

The Augmented Satellite Control Facility (SCF) will be a global network of satellite tracking stations, controlled and coordinated from a central location called the Satellite Test Center (STC), which is located at Sunnyvale, California. There will be six remote tracking stations - five in the western half of the northern hemisphere and one off the east coast of Africa. These stations are:

1. Thule Tracking Station (TTS).
2. New Hampshire Station (NHS).
3. Vandenberg Tracking Station (VTS).
4. Hawaii Tracking Station (HTS).
5. Kodiak Tracking Station (KTS).
6. Indian Ocean Station (IOS).

The locations of these stations are shown in Figure 1.

The primary function of the Augmented SCF is to provide communication and control for tests of space vehicles in the dense multiple-satellite environment of the near future. The SCF will have the capability to: (1) track orbiting satellites, (2) command vehicle-attitude changes and control special payload functions, (3) receive and process telemetered data, and (4) effect the recovery of re-entry vehicles. The Augmented SCF will be based on the presently existing SCF but will have an increased capability to support multiple, simultaneous satellite operations through the use of new tracking, data processing, and communications equipment. This increased capability includes the ability to support the following operational situations:

1. Coincident support for certain limited combinations of two different satellites having a simultaneous pass over VTS, HTS, or NHS.
2. Six satellites being processed simultaneously at the STC.
3. Simultaneous launch countdown and single-satellite pass at VTS.
4. Only one vehicle recovered during a 24-hour period.
5. A five-minute-maximum interval from the time a tracking station ceases to support one vehicle to the time it is ready to support another vehicle (a design goal).

The Augmented SCF will be able to support the following satellite systems: 162, 206, 417, 461, 626, 698BK, and 823.

Figure 1. Locations of SCF Tracking Stations

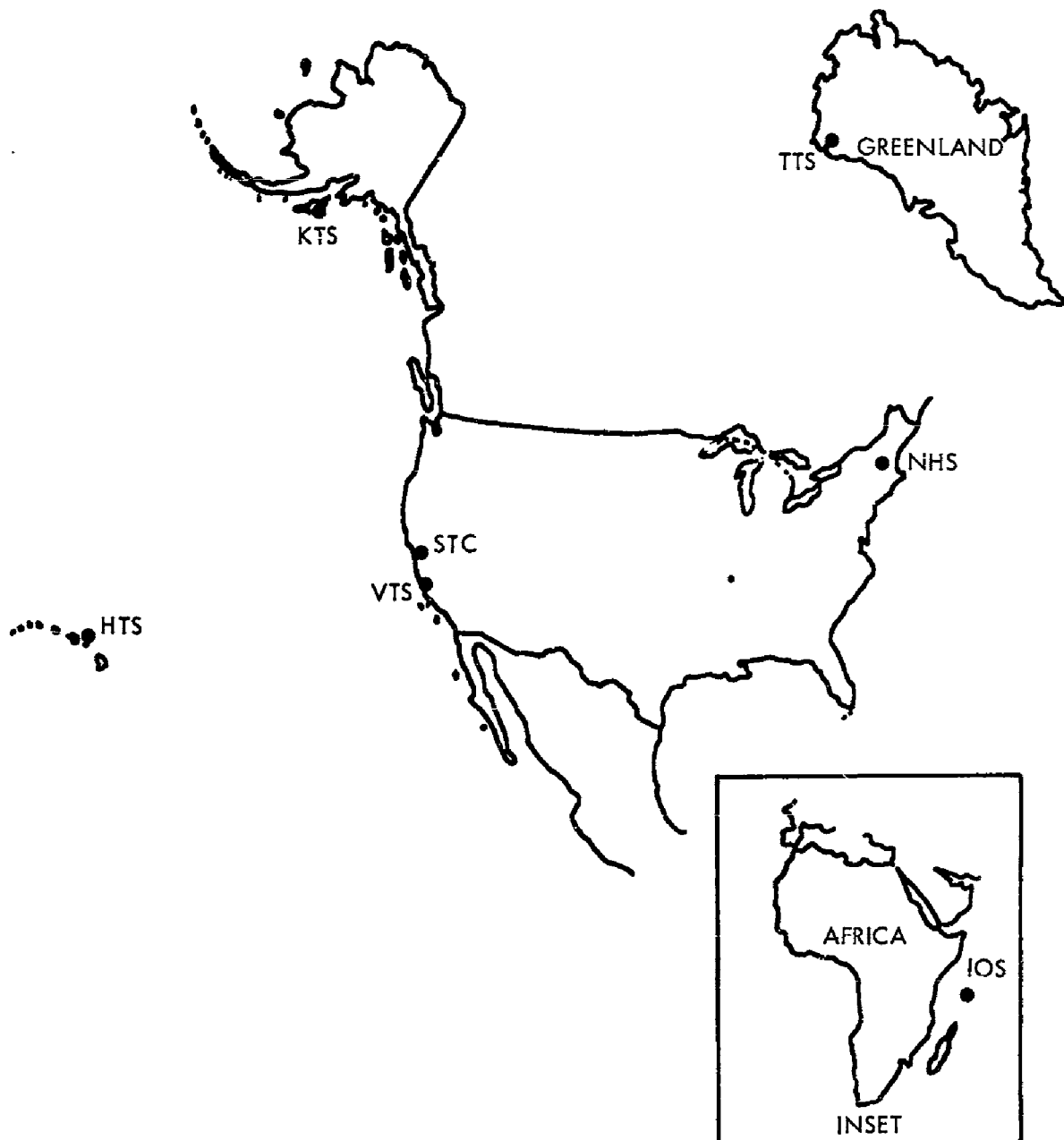

2.0 SCF EQUIPMENT

2.1 STC EQUIPMENT

The STC exercises overall control and coordination of satellite tests and the network facilities. This centralization of control is especially necessary in a multiple-satellite environment to resolve conflicts and priorities, and to insure optimum use of the SCF resources. The Augmented STC will have the capability to control six satellites simultaneously. Equipment in the STC is designed around this maximum workload. There are eight vehicle-oriented Bird Buffer computers. The two extra computers allow for a backup capability and increased flexibility. There are four CDC 1604 off-line computers, which handle the bulk of the computational work load. These two computer complexes-- the vehicle-oriented Bird Buffers and the off-line 1604's--are mated together through a programmable switch, which is under the control of a CDC 160A computer; the Bird Buffers are connected to the tracking stations through a similar switch, controlled from the same source. These switches make the system flexible and amenable to rapid reconfiguration. Figure 2 is a block diagram of the STC equipment inter-connections.

Although many of the control operations performed at the STC are automated, there is still a need for a large amount of human control and decision making. The control area is laid out so as to facilitate the handling of up to the maximum number (6) of simultaneous satellites. Figure 3 shows the layout and some of the communication facilities and display equipment available to the operators. In the center of the control area is the main control room, in which are located the Master Controller and the Test Controllers, and from which tracking station operations are directed. On the second level, and overlooking the main control room, is the Test Directors' control room, where program personnel can monitor an actual satellite operation. Adjacent to the main control room is the Multi-ops room, where Multi-ops personnel supervise the equipment time sharing and scheduling necessitated by multiple satellite operations. Also adjacent to the main control room is the Data Presentation room, where operators prepare data for display to the Test Controllers in the control room. Grouped around the main control room are six operating complexes, one for each of the six vehicles the system can control simultaneously. Each complex has several rooms where functions such as orbit planning, vehicle analysis, payload analysis, and command generation are performed under the supervision of a Test Controller. Across the hall from the main control area are six rooms reserved for the Test Directors, where they can do the necessary work of preparing for satellite operations. Some monitoring facilities are also available in these rooms to allow program personnel to follow operations during vehicle contact.

The principal communications systems available to the operators in the main control area are closed-circuit television; pneumatic tubes for passing written and graphic material; CDC 166 Buffered Line Printers in the Multi-ops, Data Presentation, and Data Analysis rooms of the various program complexes; and voice and teletype lines to the tracking stations.

The principal equipment subsystems at the STC are discussed in more detail in Sections 2.1.1 through 2.1.13 below.

2.1.1 Bird Buffer Subsystem. The Bird Buffer subsystem acts as a buffer between the tracking stations and the STC complex of test personnel and the CDC 1604 off-line computers. It operates in two modes: Non-Real-Time and Real-Time. The Real-Time mode is in effect when the tracking station is in contact with a vehicle; at that time, commanding, tracking, and telemetry data are passed between the Bird Buffer, the tracking station, and the vehicle in real time. The Non-Real-Time mode is entered when there is no vehicle contact; it is used to send prepass data to the tracking stations and to pass data to and from the 1604 computers.

The Bird Buffer program is made up of seven modules, whose specific functions are as follows:*

1. Executive Control Module (SXCON)--SXCON determines the operating sequence of the various programs, effects data transfers, and transmits system outputs to the proper equipment.
2. Command Module (SCOMD)--SCOMD has three primary functions:
 - a. Special verification of command transmission to the tracking stations (explained in detail in Section 5.0).
 - b. Processing and printout of real-time command status reports.
 - c. Postpass printout of command history.
3. Prepass Module (SPREP)--SPREP has four functions:
 - a. It maintains an updated prepass tape with TLM processing tables, command messages, antenna pointing data, scheduling messages, and text.
 - b. Upon request, it sends the prepass data to the tracking station, verifies the messages sent, and keeps an account of all data received by the station.
 - c. When a change in TLM mode is requested, it reads in the appropriate TLM processing table from the first files of the prepass tape.
 - d. Before the start of a pass, it writes on the recording tape the prepass information that the station has received for the coming pass.

* For a more detailed description, see Reference 4.

1 April 1963

11
(Page 12 blank)

TM-1146/000/00

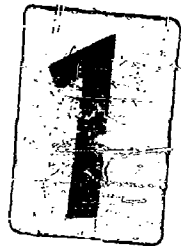
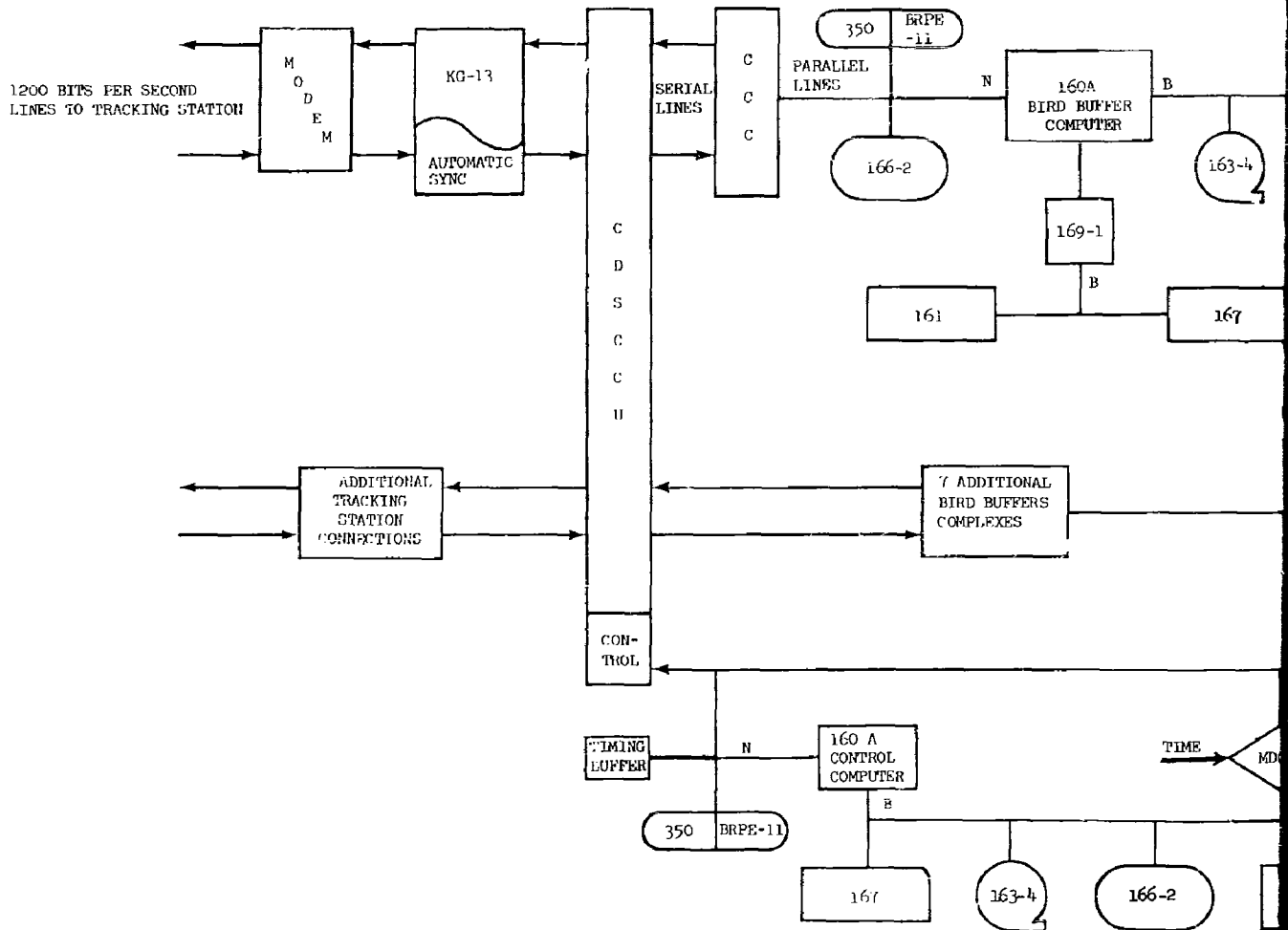

Figure 2. STC Equipment Block

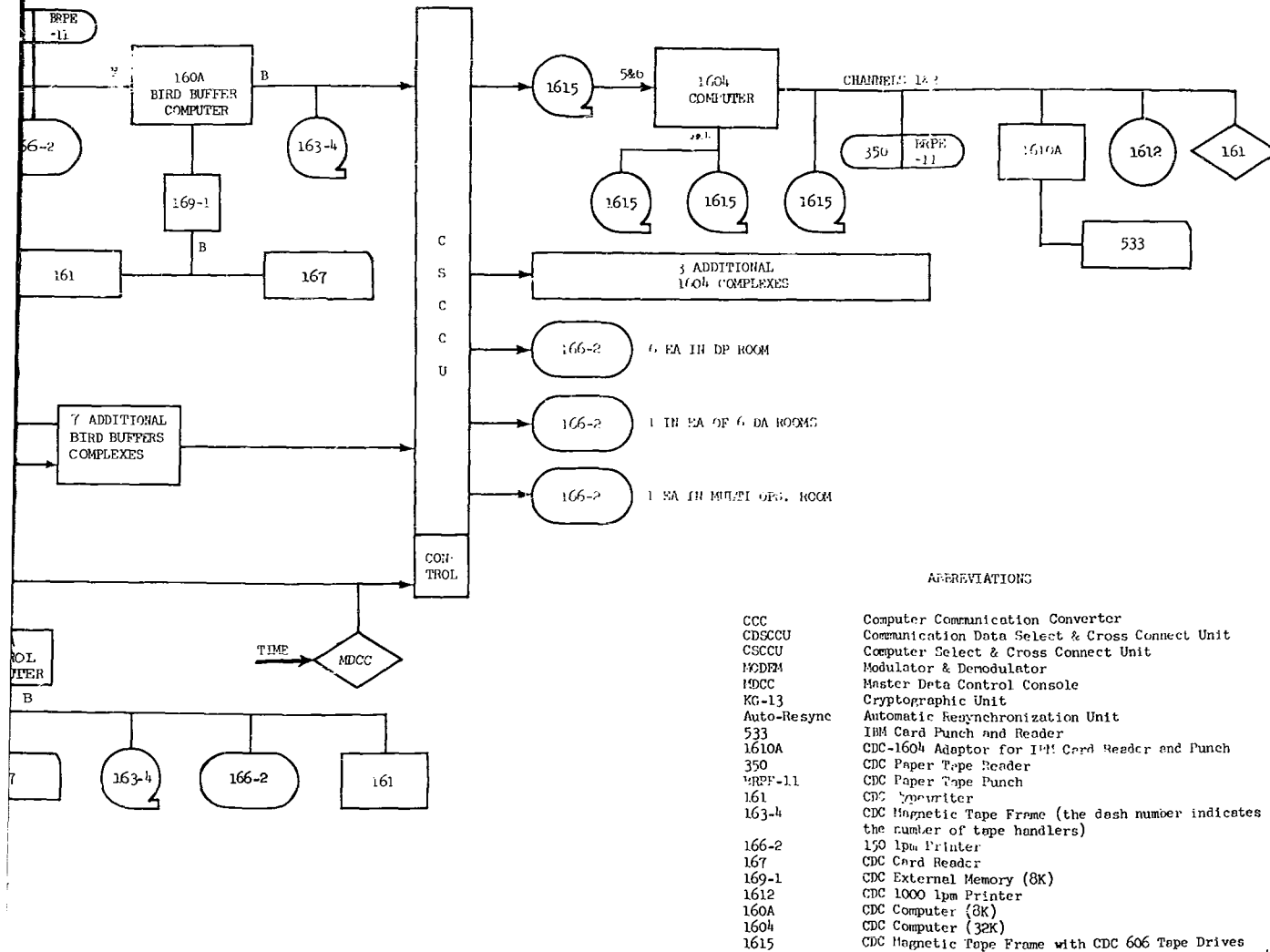

Figure 2. STC Equipment Block Diagram

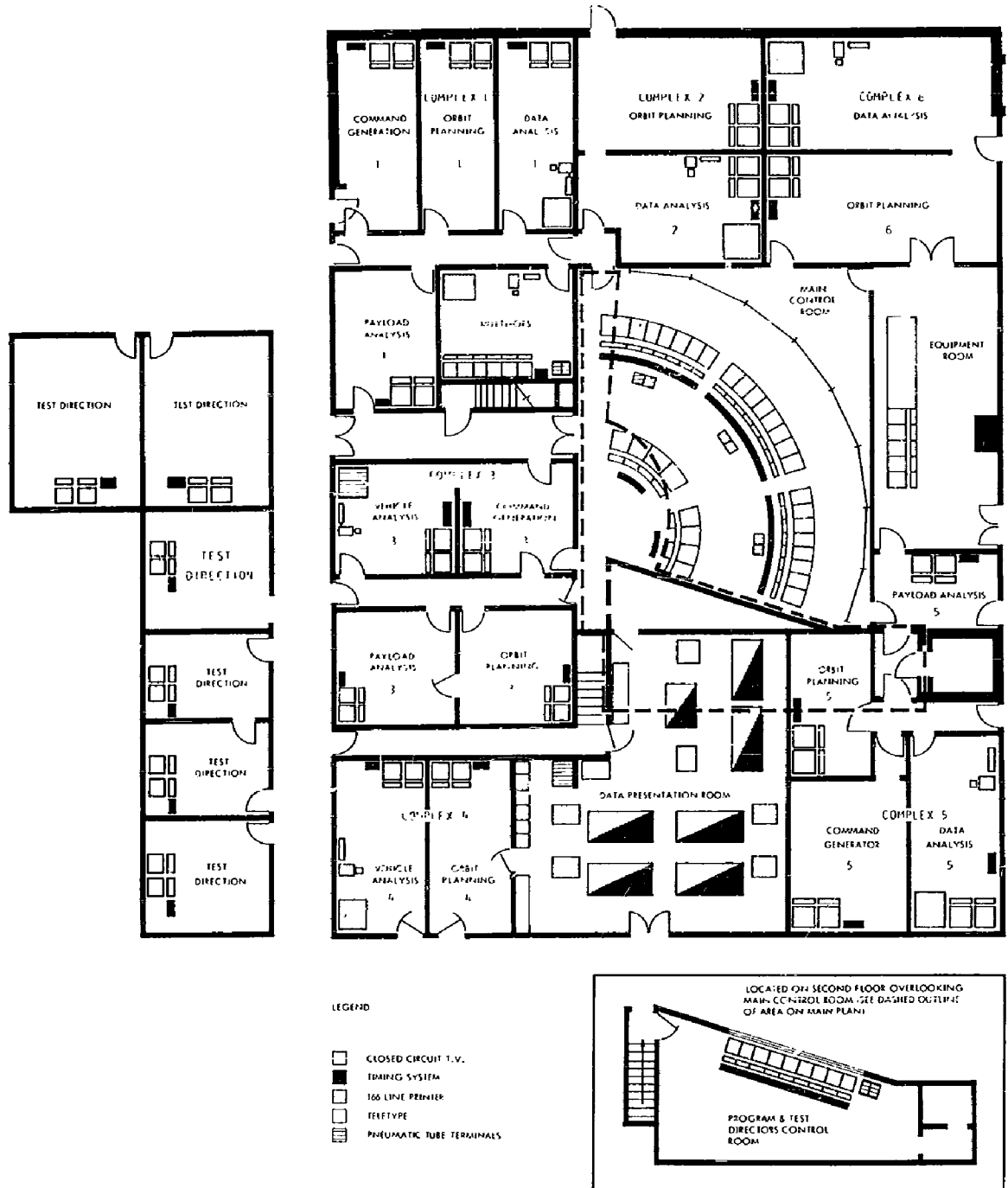

Figure 3. STC Control Area Layout

4. Telemetry Processing Module (STEPP)---STEPP accepts telemetry data from the tracking station, performs the necessary conversions to engineering units, prepares one set of selected data for printout on the Data Analysis printer and a different set for printout on the Data Presentation printer, and prepares, for printout, any alarms or status messages generated by the TIM computer at the tracking station.
5. Tracking Module (STRAK)--STRAK has three functions:
 - a. During a pass, it accepts track data from a tracking station at the rate of one message per second, formats the data for printout, and sets flags so the data will be printed out on the Data Presentation and Data Analysis printers.
 - b. On request from the 1604 computer, it searches the recording tape for the requested tracking data, reads it into core, and uses the communications subroutine SIBBTC to transfer it to the 1604. This operation is accomplished in the post-pass mode.
 - c. STRAK will print out alarm and status messages which are concerned with tracking and are received from the remote site's T&C computer. These will consist of text messages and will be transferred to the Data Analysis and Data Presentation printers as specified.
6. Communication Module (SIBBTC)--SIBBTC enables the Bird Buffer to communicate with the 1604 computer on a core-to-core basis, using the direct transfer mode of the 1615 tape units. Five types of transfers are effected by SIBBTC:
 - a. It receives prepass messages containing antenna pointing, commands, scheduling, and text information. All messages are checksummed and the command messages are retransmitted to the 1604 computer for bit-by-bit verification.
 - b. It receives commands from the 1604 computers for real-time transmission to the vehicle via the T&C computer. Each message is retransmitted to the 1604 computer for bit-by-bit verification.
 - c. It transfers vehicle-time and tracking data to the 1604 computer. These data are verified for correctness by the 1604, with a response back to the Bird Buffer.
 - d. A "Last Operation Complete" control message is sent by SIBBTC after the last block of tracking data has been sent. This function is called for by the user program and is not a decision of SIBBTC.

- e. SCHOPS data are sent by the 1604 to the Bird Buffer and SIBBTC responds as to the correctness of the data.
7. Input Processing Module (SPROC)--SPROC interprets control card inputs and causes the appropriate actions to be taken by the Bird Buffer modules. The card-input requests and the SPROC response to each request are as follows:
- a. Initialize--The Bird Buffer will identify with the vehicle number contained on the card; tapes will be rewound, system flags set to zero, and system buffers initialized.
 - b. Transfer TRK--SPROC reads the requested tracking data from the 163 tape, interrupts the 1604, and transfers the data core to core.
 - c. Transfer Prepass--SPROC interrupts the 1604 and requests the prepass data. Each message is checksummed and stored on the 163 tape.
 - d. Command History--SPROC searches the 163 for the specified pass and prints out, on the designated printers, all commands given and operational report messages received during this pass.
 - e. Merge Tape--SPROC finds the telemetry mode tables on tape, as specified on this card, and merges them onto the first part of the prepass tape.
 - f. Contact Site--A "Hello, STC to Site" message is flagged to send to the tracking station.
 - g. Send Prepass--SPROC reads the prepass data into core and flags it for transmission to the tracking station.
 - h. Transfer Card Prepass--SPROC reads prepass data from the cards and writes it on a 163 tape in the proper format for transmission to the tracking station.
 - i. Transfer SCHOPS--An interrupt and request for a tracking station's scheduling data is sent to the 1604 computer. Transfer is core to core and recording on the 163 tape is in the same format in which it is received.

- j. Restart--This card, followed by an initialize card, causes the Bird Buffer to be re-initialized.
- k. Change TRK Rate--The new rate data on the card are assembled, a check sum is calculated, and a flag is set for transmission to the T&C computer.
- l. Request Commands--SPROC interrupts and request commands from the 1604. Commands sent are verified by retransmission, then flagged to be sent immediately to the tracking station. No format change is made and the Bird Buffer does not accept a second 64-word command message until the first message has been sent to the tracking station and verified.
- m. Send Command--SPROC assembles the command message from the card input, calculates a checksum, and flags the message for transmission to the tracking station.
- n. Send Text--SPROC assembles the text message from the card input, computes a checksum, and flags it for transmission to the tracking station. It also flags the message for printout on any of the 166 printers designated.
- o. Select or Modify TLM Mode--SPROC assembles the new parameters, computes a checksum, and sets a flag for transmission of the message to the tracking station. If a new mode is requested, SPROC inputs the new mode tables from the prepass tape.
- p. Suppress TRK Printout--Periodic printout of vehicle time and tracking data is halted until a "Re-initiate TRK Printout" card is inserted. The data flow to the 163 tape is not interrupted.
- q. Re-initiate TRK Printout--This card restarts the printout of tracking data on the 166 printers.
- r. END--This notifies SPROC of the end of an input which is contained on more than one card. All cards following the end card are disregarded until another control card is encountered.

A Bird Buffer subsystem consists of the following equipment (see Figure 2).

1. One CDC 160A computer.
2. One CDC 169-1 auxiliary memory, which gives a total high-speed core-memory capability of 16,384 twelve-bit words.
3. One 160A-P phantom resume, which gives a response to the 160A when an equipment selected by it is not available. It is mounted on the CDC-161 typewriter.
4. One 160 A-D amplifier unit. This is a set of line amplifiers, which enable the 160A computer to drive equipment located up to 500 feet away.
5. One CDC 161 input/output typewriter on the CDC 169 buffer channel.
6. One 350 paper-tape reader on the 160A normal channel.
7. One BRPE-11 paper-tape punch on the 160A normal channel.
8. One CDC 163-4 magnetic-tape unit on the 160A buffer channel.
9. One CDC 167-2 card reader on the CDC 169 buffer channel.
10. One CDC 166-2 printer on the 160A normal channel.
11. One CCC on the 160A normal channel. It will have two input spigots to the Bird Buffer--one from the TLM computer and the other from the T&C computer.

The Bird Buffer system interfaces with the CDC-1604 off-line computers through CDC-1615 magnetic tape units operating in the satellite mode. All transfers between these two computers are on a core-to-core basis. The CSCCU connects the Bird Buffer to a 1604 computer in accordance with the SCHOPS schedule or through manual intervention by the MDCC operator. Thirteen remote 166-2 printers are shared by all Bird Buffers; up to three of them can be connected to the 160A buffer channel at one time. The printers are connected to the Bird Buffer by the CSCCU.

2.1.2 CDC 1604 Computer Subsystems. These subsystems consist of four computers and their peripheral equipment. The four computers operate independently of each other. In contrast to the Bird Buffers, which are vehicle oriented, the 1604's do not usually support vehicles in real time; they are normally operated off line and on demand. (However, there are cases in which real-time support of a vehicle may be necessary because of urgent time considerations. Some of these cases are: (1) initial orbit determination, (2) re-entry impact-point determination immediately after receipt of re-entry tracking data, and (3) generation of emergency alternate command messages.)

The 1604's are time shared by all satellite-program users, with the actual schedule of usage being prepared by SCHOPS and Multi-ops personnel. Four main functions are performed by the 1604's:

1. Orbit determination and prediction.
2. Ascent and re-entry calculations.
3. Preparation of vehicle command messages.
4. Production of SCHOPS schedules.

A brief description of these functions is given below, with the exception of the SCHOPS function, which is described in Section 6.0.*

Orbit determination and prediction involves the collecting of tracking data from the launch site and tracking stations, and the use of these data to generate ephemerides for the active satellites in the system. The scheduling of the SCF equipment and human resources depends on these derived data. The specific operations performed by the Orbit Determination and Prediction programs are:

1. Receive raw tracking data from the launch site and tracking stations via the Bird Buffer Subsystem.
2. Screen and process the raw tracking data to obtain updated orbital elements.
3. Print out the raw tracking data for visual analysis.
4. Use nominal or actual orbital elements to calculate vehicle acquisition rise and set times for SCF and SPADATS tracking stations.
5. Use nominal or actual orbital elements to generate vehicle ephemerides over designated time periods.

*For more detailed descriptions of the functions, see References 6 and 10.

6. Provide for data fitting and tracking data prediction over an orbit adjust.
7. Maintain the capability to select and combine orbital vectors to obtain updated orbital elements.
8. Generate data for driving antennas at tracking stations.

The Ascent and Re-entry programs support the critical phases of a satellite's operational life by performing the following operations:

1. Process nominal vehicle ascent parameters to provide tracking station antenna pointing data for vehicle ascent.
2. Produce a nominal ascent ephemeris.
3. Process data from weather balloons to determine wind shear and its effect upon booster performance.
4. Reduce ascent tracking data received from tracking stations and determine orbital-injection parameters.
5. Provide the capability to establish a nominal orbit with nominal injection conditions.
6. Predict the time to start the re-entry thrust stage, based upon desired impact location
7. Determine nominal re-entry impact location, based upon the time of thrust start.
8. Receive, screen, and process raw re-entry tracking data to determine the impact point location.
9. Provide a re-entry ephemeris and antenna pointing data for driving antennas and for use by operations personnel.

The vehicle command messages that are transmitted to the vehicle by the tracking station are assembled and formatted by the Vehicle Command programs. (Initiation, transmission, and verification of commands are discussed in Section 5.0). Operations performed by the Vehicle Command programs are:

1. Generate Real Time Commands (RTC) and Stored Program Commands (SPC).

2. Determine required Auxiliary Real Time Commands (ATC) to control the Fairchild Timer operation.
3. Update command tables, based upon commands being transmitted to and verified by the vehicle.
4. Establish the relationship between vehicle and system time.

The 1604 computers interface with the vehicle-oriented Bird Buffers through the intermediary of the 1615 tape unit operating in the satellite mode. The working time assignments for the 1604 are determined by the SCHOPS schedule under the direction of Multi-ops personnel. Actual connection to a Bird Buffer is through the CSCCU, under the control of the Switch Control Computer. A 1604 subsystem, with its peripheral equipment, consists of:

1. One CDC 1604 Computer.
2. Four CDC 1615 Tape Units.
3. One CDC 1612 On-Line Printer.
4. One IBM 088, 80-column Card Reader.
5. One IBM 523, 80-column Card Punch.
6. One CDC BRPE-11 Paper Tape Punch.
7. One CDC 350 Paper Tape Reader.

2.1.3 Communication Data Select and Cross Connect Unit (CDSCCU) and Computer Select and Cross Connect Unit (CSCCU). The capability that the Augmented SCF has to handle multiple-satellite operations is in large part dependent upon being able to rapidly connect and disconnect the equipment arrays at the STA that are necessary to support the varied high load situation encountered in a dense satellite environment. The designs of the CDSCCU and CSCCU are such that great flexibility is allowed in setting up and reconfiguring the equipment complexes demanded by the rapidly changing conditions.

The CDSCCU and CSCCU are switching devices used to interconnect the communications and data-processing facilities at the STC. The CDSCCU connects the Bird Buffers with the terminal equipment of the 1200-bps communication lines which connect with the tracking stations. The CSCCU connects the Bird Buffers to the 1604 computers through the CDC 1615 magnetic tape units operating in the satellite mode, and to the CDC-166 printers (See Figure 2). These switching units are under the control of the 160A Switch Control Computer (SCC) and the Master Data Control Console (MDCC).

The CDSCCU, by switching a Bird Buffer from one tracking-station line to another, enables the Bird Buffer to process all the data from a given satellite as contact with it passes among the various tracking stations in the SCF network. The actual interfaces of the CDSCCU are with the Computer Communication Converter (CCC) on the Bird Buffer side, and with the KG-13 cryptographic equipment on the line side. The initial capacity of the switch is 12 KG-13's and 8 CCC's. Each cross point is a relay with 20 break-before-make contacts. Four of these contacts are used for duplex serial input/output data, eleven are for control between the CCC and Autoresync, and five are spares.

The CSCCU, by switching a Bird Buffer from among the available 1604's, makes possible the best use of the available computer capacity. The CSCCU differs from the CDSCCU in that multiple connections may be made on the 1604 side of the switch so that more than one 166 printer may be connected to a Bird Buffer. Also, on the CSCCU, there is a Security mode, which can be used to restrict certain printers from being connected to certain Bird Buffers by the control computer or by override from the MDCC. The initial capability of the CSCCU is eight Bird Buffers on one side by twenty connections on the other (four 1615's, thirteen 166-2's and three spares). It has a growth potential to thirty-two Bird Buffers by sixty-four 1615's and 166's. Each cross-point connection has forty break-before-make contacts, thirty-six of which are wired. Of the thirty-six wired contacts, twenty-four are used for duplex parallel input/output data and twelve are for control between the tape storage units and the Bird Buffer.

2.1.4 CDC 160A Switch Control Computer. The principal functions of the Switch Control Computer (SCC) are to control the operations of the CDSCCU and CSCCU in response to the SCHOPS-generated master schedule tape and to monitor the switch actions controlled from the Master Data Control Console (MDCC). The SCC maintains status information on all of the cross point connections of the two cross-connect units. At regular intervals (one hour), and on request from the MDCC, this status is printed out on the 166 printer located at the MDCC.

There are five modes of operation of the SCC: (1) Normal, (2) Card Override, (3) Cards-only, (4) Status, and (5) Interrupt. The Normal mode operation processes a SCHOPS tape input to provide output commands that control the CDSCCU and CSCCU. In the Card Override mode, card inputs can modify the SCHOPS schedule. The Cards-Only mode puts all switch operations under control of the input cards. The Status mode allows checking of the actual switch status with the SCHOPS schedule; discrepancies are noted and explained on the printout. The Interrupt mode allows interruption of the SCC by its peripheral equipment (Figure 2). As most routines cannot be interrupted, interrupts are held active so that they can be processed after the routine being processed is completed.

The SCC is supplied with system time by the Computer Timing Buffer Equipment (CTBE). Time is stored in memory, where it is periodically compared with the switch times listed on the SCHOPS-generated master schedule. When the schedule time for a cross-point-connection change is reached, the SCC outputs a command to the switching unit concerned. The status table is then updated

for each valid command. If the command was not successful in changing the cross-point connection, the response word from the switch unit is analyzed and an alarm is printed on the MDCC 166 printer. Invalid commands, such as commands for units in a Maintenance mode or commands which set a cross-point connection to its existing position, are not sent to the switching units.

The equipment associated with the 160A Switch Control Computer is as follows (see Figure 2):

1. Computer Timing Buffer Equipment (CTBE).
2. CDC 167 Card Reader.
3. CDC 350 Paper Tape Reader.
4. CDC BRPE - 11 Paper Tape Punch.
5. CDC 161 Electric Typewriter.
6. CDC 163-4 Magnetic Tape Handler.
7. CDC 166 Printer.
8. CDSCCU.
9. CSCCU.

2.1.5 Master Data Control Console. The Master Data Control Console (MDCC) is the central monitor of the data-processing system at the STC. It also functions as a backup to the 160A Switch Control Computer (SCC) in controlling the CDSCCU and CSCCU. In this capacity, it has three operating modes: (1) Dual Control, (2) Manual Lockout, and (3) Manual Control.

When operating in the Dual Control mode, the MDCC can command the connect or disconnect of any cross-point connection in the CDSCCU and CSCCU. In this mode, the SCC has the same capability to control the switches as the MDCC. Thus, the CDSCCU and the CSCCU respond to commands from either of these sources and either source can change any cross-point connection at any time.

In the Manual Lockout mode, the MDCC has the same control of the switches as in the previous mode but can exclude the control of the SCC over any selected cross-point connection. By means of a lockout command, manually executed in conjunction with any connect or disconnect, the MDCC can prevent the SCC from changing that connection. This lockout condition is removed when a subsequent manual selection, without a lockout command, is made for that cross-point connection.

In the Manual Control mode, the SCC is prevented from making cross-point connects or disconnects. All switch changes are made manually from the MDCC. Changing from one mode of operation to the other does not in itself change any existing cross-point connections.

The MDCC will have displays which indicate the status of all cross-point connections in the CDSCCU and CSCCU, including the "lockout" condition of the Manual Lockout mode. Timing displays available at the MDCC are: (1) universal time in one-second intervals up to 23 hours, 59 minutes, and 59 seconds; and (2) system time in seconds up to 86,399 seconds.

A communications panel is available on the MDCC to allow the operator access to the intra-station and inter-station voice-communication networks. The MDCC is provided with a CDC-161 input/output typewriter for communication with the SCC.

All cross-point connections made by the MDCC are monitored by the SCC and a record of these actions is output on the MDCC 166 printer.

2.1.6 CDC 1604 Computer. The CDC 1604 is an all-transistorized, stored-program, general-purpose digital computer. It has a storage capacity of 32,768 forty-eight-bit words. Following are some of the 1604 features:

1. Parallel mode of operation.
2. Single-address logic, two instructions per 48-bit word:
 - operation code-----6 bits
 - designator-----3 bits
 - base execution address--15 bits
3. Six index registers.
4. Storage in two independent 16,384 word banks, alternately phased.
 - 4.8 microseconds effective cycle time (overlapping cycles)
 - 6.4 microseconds total cycle time
5. Input/output facilities:
 - Three 48-bit buffer input channels
 - Three 48-bit buffer output registers
 - One high-speed, 48-bit, input-transfer channel (4.8 micro seconds, 48-bit parallel word)
6. Program interrupt.

In the 1604, input/output operations are carried out independently of the main computer program. When transmission of data is required, the main computer program is used only to initiate an automatic cycle, which buffers data to and from the computer memory. The main computer program then continues while the actual buffering of data is carried out independently and automatically.

The input/output section of the 1604 contains facilities for several modes of communication. For normal exchange of data with peripheral equipment, independent control is provided for the transfer of data via three 48-bit buffer input channels and three 48-bit buffer output channels. These channels operate asynchronously with the main computer program. For high-speed communication, one 48-bit input-transfer channel and one 48-bit output-transfer channel are provided so that two or more 1604's can communicate with each other. Communication control is performed by the external function instruction. In addition, the interrupt feature provides requests from peripheral equipment to the computer. See Section 2.1.8 for a description of the 1604 Satellite mode of operation with a CDC 160A computer.

2.1.7 CDC 160A Computer. The CDC 160A computer is a flexible, multi-purpose, stored-program data processor and converter. It employs high speed ($2\frac{1}{2}$ megacycle clock frequency) transistor amplifier circuits, diode logic, and a magnetic-core matrix memory. Word construction is 12 binary digits, parallel throughout, programmable to multi-precision and to alpha-numeric and binary-coded decimal.

The basic memory of the 160A computer consists of two units (banks) of magnetic-core storage, each with a capacity of 4096 twelve-bit binary words and a storage cycle time of 6.4 microseconds. The internal program will automatically switch from one storage bank to another, depending on the addressing mode. The switch can also be accomplished by instructions which specifically assign and/or select the reference for a particular bank. This basic memory may be expanded in modules of 8,192 words, up to a maximum of 32,768 words. Instructions are executed in one to four storage cycles; the time varies between 6.4 and 25.6 microseconds. The average program time for executing the repertoire of 130 basic instructions is approximately 15 microseconds per instruction.

A general-purpose input-channel and output-channel system is provided for attaching a variety of input/output devices. Input and output transmissions are either a single 6-bit, 7-bit, or 8-bit character, or a 12-bit word. Standard input/output is by punched-paper-tape, high-speed, read-and-punch units. Optionally, other input/output devices, such as on-line typewriter, magnetic-tape handlers, punched-card units, digital communication units, analog-to-digital converters, or other similar equipment may be added.

A buffer input/output channel permits the computer to continue high-speed computation while communicating with external equipment. Any peripheral unit connected to the buffer channel may also be addressed, using the normal input/output channel.

Four interrupt lines, including a manual interrupt, allow effective use of computer time.

Operation of the 160A computer is sequenced by an internally stored program. This program, as well as the data being processed, is contained in the high-speed, random-access storage. An instruction is a 12-bit word comprising a 6-bit function code and a 6-bit code extension and/or execution address. Program modifications are accomplished and operands are manipulated by direct, relative, or indirect addressing. The 160A is constructed in a standard-size office desk.

2.1.8 CDC 1615 Magnetic Tape Unit. The CDC 1615 is an optional input/output and auxiliary-memory storage device for the CDC 1604 computer. It is comprised of four CDC-606 digital tape handlers and a synchronizer control unit, all housed in a single cabinet. Each tape unit handles and processes plastic-base tape on which data are stored as magnetized spots. The synchronizer buffers and controls the flow of data between the computer and the individual tape units. Transfer of data from computer memory to magnetic tapes, and vice versa, and exchange of control information is accomplished through coded, programmed, external-function instructions.

Tape speed during reading and writing operations is 150 inches per second; the maximum character transfer rate is 83,400 characters per second. A seven-track, non-return-to-zero recording scheme is used. Six tracks are assigned to the data (termed a character) and one track contains a parity check bit for the character. A character and its parity bit comprise a line of tape data. Data are recorded in two formats: binary and binary-coded decimal (coded). The parity bit is chosen to make the total number of "1" bits in a line odd in binary format and even in coded format. Data are recorded on the tape at a selectable density of 556 or 200 lines per inch in records of varying length.

In the Satellite mode of operation, a 1604 computer communicates with a 160A computer through the 1615. Both computers have access to the tape units and simultaneous read and write operations may take place. The 160A communicates on a 12-bit, two-way channel and the 1604 communicates on two 48-bit channels. The 160A may write while the 1604 reads, or vice versa, but the read or write control can be used by only one computer at a time. An additional feature is a 6-bit path from the write-channel control to the read-channel control, which bypasses the tape completely and allows direct transfer of data between computers. The rate of data transfer in this mode is dependent only on the transfer rates of the computers. For the 1604, the word-transfer rate (8 characters) is 5,000 wps min and 50,000 wps maximum. The 160A word-transfer rate (2 characters) is 80,000 wps.

2.1.9 CDC 166 Line Printer. The CDC 166 Line Printer is a 188-line-per-minute buffered printer, with 120 character positions per line. It can be connected and controlled on line from the CDC 160A. That is, data can be processed and formatted in the computer and then sent to the 166 for printing. The 166 can also be used in an off-line tape-to-printer mode.

2.1.10 CDC 1612 Line Printer. The CDC 162 Line Printer is a data-output device designed to work in direct communication with the CDC 1604 or 160A computers. Its characteristics are:

1. Printing Rate--1000 lpm.
2. Maximum Paper Speed--9000 lpm.
3. Line Length--120 columns.
4. Line Spacing--6 lines per inch.
5. Character Spacing--10 per inch (on line).
6. Number of Characters--64 including blanks.

2.1.11 CDC 163 Magnetic Tape Unit. The CDC 163 Magnetic Tape Unit is a high-speed input/output device consisting of control logic and several magnetic-tape handlers. The unit has a maximum transfer rate of 15,000 twelve-bit words per second, and its data format can be either binary or BCD.

2.1.12 CDC 169 Auxiliary Memory Unit. The CDC 169 Auxiliary Memory Unit connects on line to one or two 160A computers. The unit increases the storage capacity of the 160A in modules of 8192 words, up to a maximum additional capacity of 24,576 words, and provides the computers with an additional input/output buffer. This buffer, once addressed, operates independently of the computers. (The number following the dash, as in CDC 169-1, indicates the number of 8192-word modules that are in the auxiliary memory; thus, a CDC 169-1 gives a CDC 160A computer a total memory capacity of 16,384 words.)

The auxiliary memory unit makes up to five peripheral equipments and six external memory banks available to either computer. Since external buffer and memory circuits function independently, one computer can initiate an external buffer operation while the other uses an external memory module. As long as the computers select separate modules, concurrent external memory references are possible. The unit resolves multiple requests for a single module on a word-by-word, equal-share basis. The 169 cabinet holds one, two, or three external memory modules. Each module has two 4096 twelve-bit word banks, identical to those of the 160A internal memory. A basic twelve-bit storage address designates a word location in an internal or external bank. Storage cycle time is 6.4 microseconds.

The computer storage bank controls specify four functional banks:

1. Relative (for instructions).
2. Direct (for constants).
3. Indirect (for operands).
4. Buffer (for internal buffered I/O data).

Programmed or manual bank selection by the 160A determines the physical bank to be used (banks 0 and 1 in the 160A, banks 2 through 7 in the 169).

A bank can represent more than one functional bank. Several banks cannot operate concurrently as one functional bank. For example, to have banks 2 and 4 represent the relative bank, the computer must make two bank selections, negating the first before selecting the second.

Independent storage cycles eliminate the need for synchronization between external memory modules. The external buffer and computers share access to each external-memory module. Each module contains a scanner, which continually monitors module-access requests from the computers or external buffer. When it detects such a request, the scanner stops and the module storage cycle starts. During the last quarter of this cycle, the scanning resumes. One device cannot monopolize a module. If the computers and the external buffer try to make concurrent storage references in a module, the scanner allows first one, then another, and finally the third device to use the memory. In the most unfavorable case, the waiting period between storage cycles cannot exceed 16 microseconds. In the most favorable case (one device continuously interrogating a particular module), the scanner cycles back during the fourth quarter of the cycle so that there is no delay between storage references.

The external buffer is an input/output circuit that transfers information between the external memory and peripheral equipment at rates up to 125 kc. Operation of the external buffer is independent of the computer, once the buffer mode has been initiated. During this time, the computer can select another equipment or perform internal computation. The 160A can simultaneously perform input/output operations on the internal buffer channel, external buffer channel (via the 169), and normal input/output channel.

2.1.13 CDC 161 Typewriter Unit. The CDC 161 Typewriter Unit is an optional input/output device for the 160A Computer System. The unit consists of an IBM electric typewriter modified by Soroban Engineering, Inc. , and a control chassis. The typewriter, which operates at a rate of approximately 10-to-12 output characters per second, may be used as a keyboard input device or as an output device for producing printed copy.

Control panel switches and indicators allow the operator to monitor and manually control the operations.

Information passes between the typewriter unit and the computer via two cables, which connect at the bottom wiring side of the logic chassis. Wires jumper these two cable connectors to allow other equipment to communicate with the computer on the same communication paths. If more than one typewriter is included in the system, internal biasing changes are required. The typewriter unit provides the computer with a flexible input/output monitoring device. Through this medium, data may be entered manually into the computer, or, in the output mode, monitoring information in a printed form may be received from the computer.

2.2 TRACKING STATION EQUIPMENT

The six Augmented tracking stations in the SCF (see Figure 1) will have major equipment additions and will be connected to the STC with duplex 1200-bit-per-second data lines. (IOS, however, will have 100-wpm telemetry lines for an indefinite time.) The major subsystems at the six Augmented stations are:

1. Two Antenna subsystems (one for telemetry, the other for tracking and commanding).
2. One Telemetry Data Processor (TDP), one FM/FM Ground Station, and peripheral equipment.
3. One Station Operator's Console (SOC).
4. One Input/Output Buffer (IOB) and Command Logic Equipment (CLE).
5. One Data Processing subsystem (two 160A computers with their peripheral equipment--one for telemetry, the other for tracking and commanding).

In addition to the above equipments, three of the Augmented stations (VTS, NHS, and HTS) have duplicate data-processing subsystems and various other equipments. These additional facilities give them a limited capability to support two satellites simultaneously. Certain combinations of satellite systems may be supported simultaneously and others may not, depending upon the particular requirements for ground support equipment that each satellite has and the capabilities of the various stations to satisfy these requirements.

In addition to the standard configurations discussed above, some of the Augmented stations will have satellite-specific equipment, such as 400-mc receiving/commanding equipment, PCM telemetry equipment, and GP-1 Ground Station equipment. Reference 11 lists the individual station equipment configurations in greater detail. Figure 4 shows the configuration of a typical augmented station and

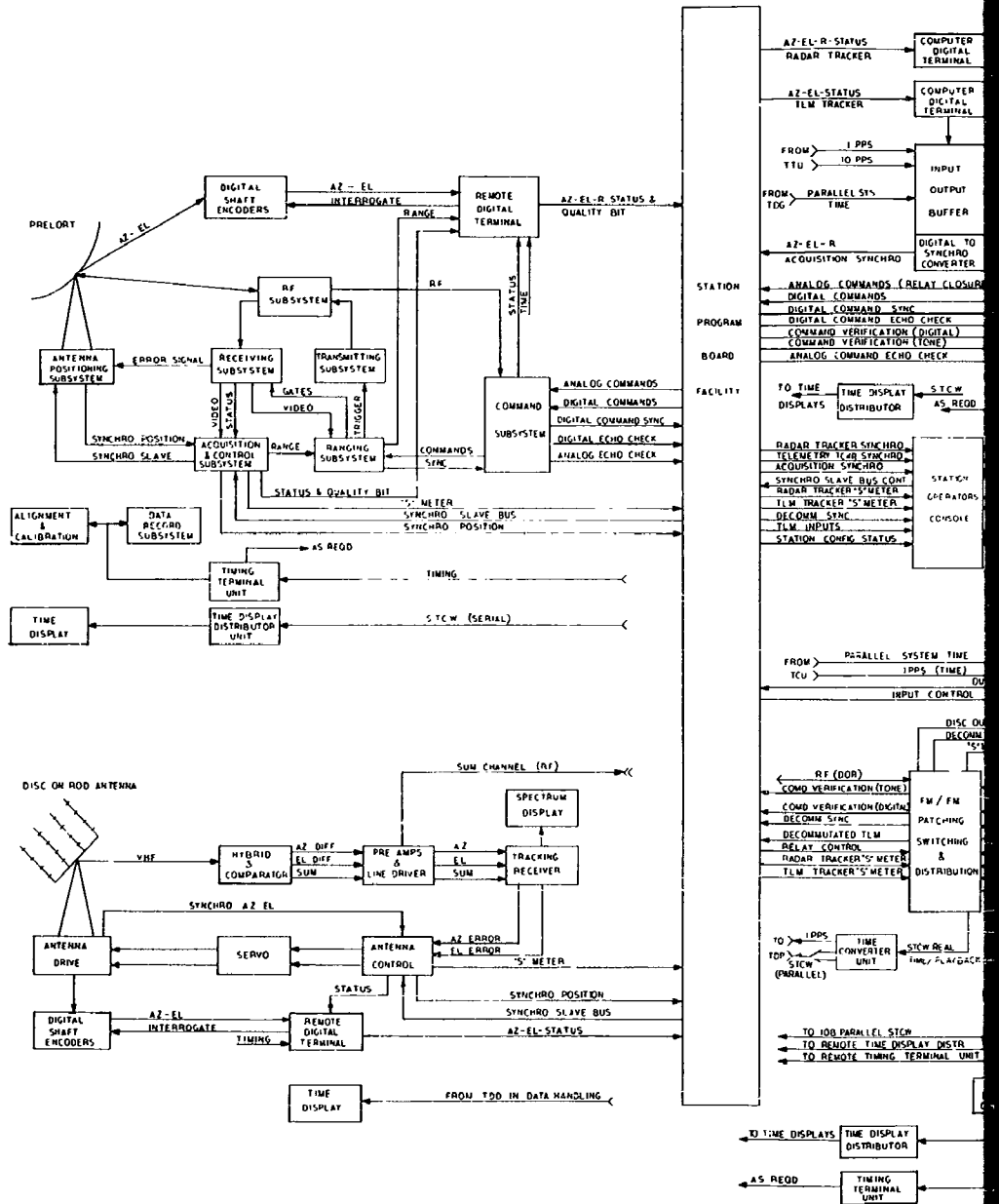

Figure 4. Typical Augmented Tracking Station

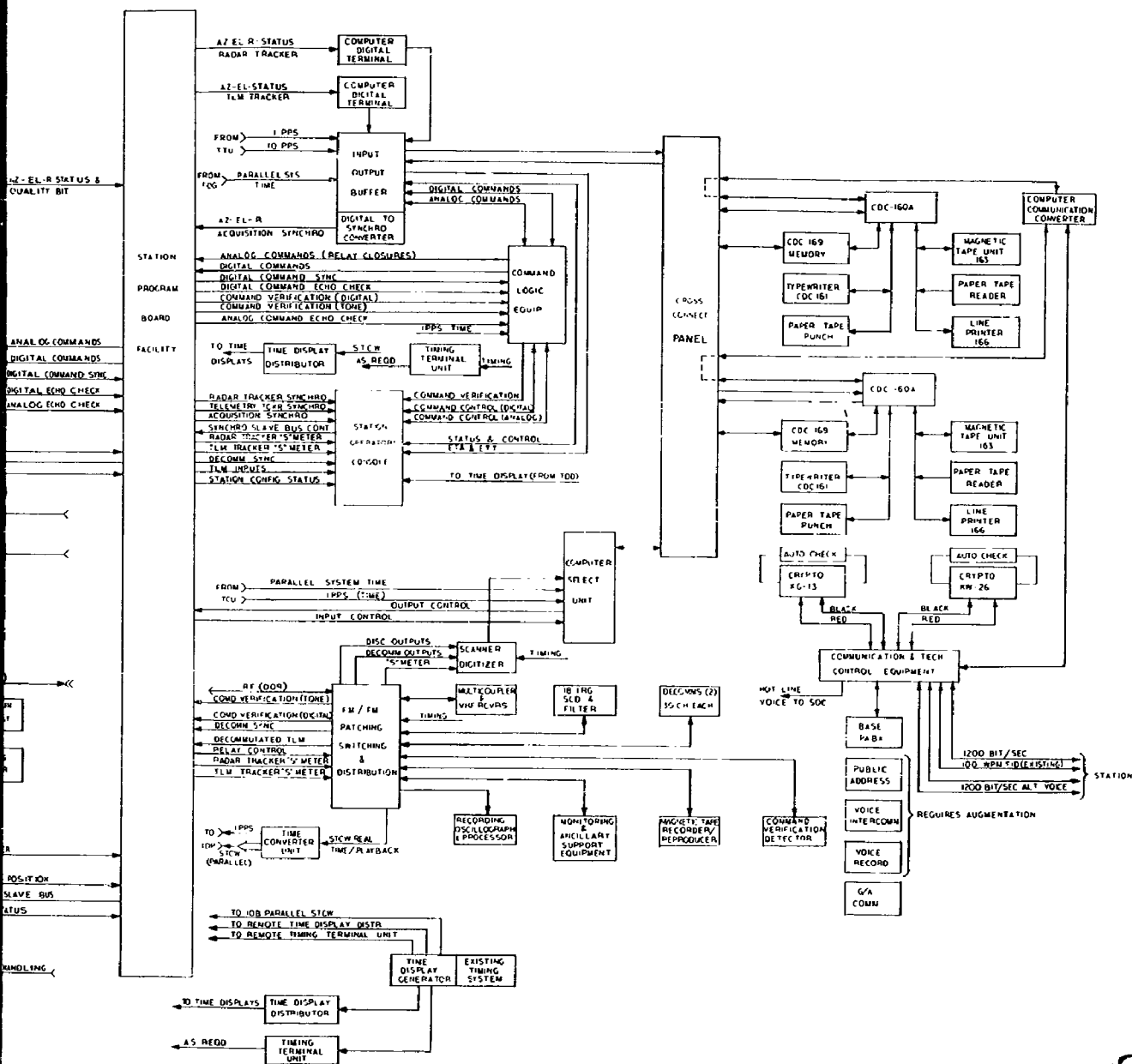

Figure 4. Typical Augmented Tracking Station Block Diagram



Figure 5 lists the antenna systems that will exist at the various stations.

The tracking station equipment can be grouped into three main subsystem categories:

1. Antenna subsystems.
2. Telemetry, Tracking and Command subsystems.
3. Data Processing subsystem.

Flexibility of operation is assured by interconnecting these subsystems through patchboards. The Telemetry, Tracking, and Command subsystems are connected to the Antenna subsystems by the Station Patchboard and to the Data Processing subsystem by the Cross Connect Panel.

These interconnections are determined at the STC with the aid of the SCHOPS scheduling program. A schedule is provided to the station operators, which assures the best use of the available equipment to accomplish the multiple satellite control mission.

The three main equipment subsystems groupings are discussed in more detail in Sections 2.2.1 through 2.2.3 below.

2.2.1 Antenna Subsystems. The Antenna subsystems are the primary data-input devices of the SCF. They are in direct contact with the orbiting vehicles. The standard configuration at each tracking station consists of two Antenna subsystems, one for telemetry and the other for tracking and commanding. Modifications to some Antenna subsystems provide additional capabilities. Some extra equipment, including antennas, has been installed at certain stations for use by a specific satellite system. For these reasons, the antenna configurations at the various stations are not identical. Figure 5 lists the major Antenna subsystems that will be used at the different stations.

Brief descriptions of the operating characteristics of the principal Antenna subsystems used in the Augmented SCF are given in Sections 2.2.1.1 through 2.2.1.6 below.

2.2.1.1 Verlort Radar. The Verlort is an S-Band radar operating in the 2.7-to-2.9-kmc frequency band. It transmits interrogation pulses to a transponder in the orbiting vehicle and tracks the return signals. Tracking data are furnished in azimuth, elevation, and range. The radar has a 10-foot-diameter, 37-db-gain, parabolic reflector. Verlort has an effective range of 5000 miles. The feed assembly furnishes a 30-cps conical scan, which produces an error signal to drive the antenna positioning servos. The peak

power output is 325 KW, the "main bang" pulse width is 0.8 microseconds, and the prf rates are 410, 512, 584, and 610. (More detailed system specifications are listed in Reference 3.) The radar transmits a 3-pulse code (two 0.25 microseconds pulses precede the main bang). The first pulse position with respect to the main bang provides a code address to identify a particular vehicle transponder. Command data are transmitted by means of the middle pulse (see Section 5.0).

The maximum automatic tracking rates are 10 degrees per second in azimuth and elevation, and 10,000 yards per second in range. The angular and range accuracies are 0.3 degree and 2500 feet respectively.

2.2.1.2 Prelort Radar. The Prelort radar is an S-band radar covering the same frequency band and having the same general operating characteristics as the Verlort radar. It represents a major modification to the Verlort with improved resolution and accuracy. It has a new 14-foot-diameter parabolic reflector with an improved feed system, a new precision pedestal with improved servo drive system and digital encoders, and low-noise-figure parametric pre-amplifiers. These improvements greatly increase the tracking accuracy in azimuth and elevation over that of the Verlort. The range accuracy remains the same as for the Verlort.

2.2.1.3 Telemetry and Data (T&D) Antenna. The T&D Antenna is a passive telemetry receiving system originally designed to operate in the 2.2-to-2.3-kmc band. All T&D Antennas in use in the SCF have been modified to also receive telemetry signals in the 225-to-245-mc band. Some of these have been further modified to receive telemetry signals in the 375-to-400 mc band. All have been modified to have auto-track capability in either the 2.2-to-2.3 kmc band or the 375-to-400-mc band. The antenna has a 60-foot parabolic reflector giving a gain of from 28 db to 49 db and a beam width of between 3 degrees and 0.5 degree, depending on the frequency band being used. In addition to the antenna being automatically positioned in the Auto-Track mode, it can also be manually positioned or driven from the slave data bus. Preamplifiers are installed at the antenna for all frequency bands. Remote receivers for the 2.2-to-2.3-kmc band of frequencies are part of the antenna system. These receivers have a maximum sensitivity of about -134 dbm. The amplified RF signals from the other two frequency bands are fed to external telemetry receivers. A doppler receiver can be used with the antenna to extract doppler velocity information from the received signals in the 375-to-400-mc band in those antennas where the modification to receive this frequency band exists.

2.2.1.4 TLM-18 Telemetry Antenna. The TLM-18 Antenna subsystem passively tracks VHF telemetry signals in the 215-to-260-mc frequency band. Its principal function is to receive telemetry data from orbiting vehicles but it also supplies azimuth and elevation angle information on the vehicle it is tracking. The antenna has a 60-foot-diameter, 28-db-gain, parabolic reflector. The feed assembly furnishes a 10-cps-conical-scan modulation, which produces an error

CP AUGMENTED TRACKING STATION EQUIPMENT CONFIGURATIONS

SUB-SYSTEM TRACKING STATION	ANTENNA SUBSYSTEMS					TELEMETRY, TRACKING AND COMMAND SUBSYSTEMS				
	PRELORT	VERLORT	TWD - SEE NOTE 1 -	TM-1B - SEE NOTE 2 -	DOR - SEE NOTE 3 -	TRU-HELIX	FM/FM GROUND STA. - SEE NOTE 4 -	GP-1 GROUND STA.	400-MC RECEIVING- COMMANDING (DOPPLER)	PCM EQUIPMENT
TTS	X				X		X			
KTS	X				X		X			
RBS 1	X				X		X	X		X
RBS 2			X				X	X	X	X
RBS 1	X			X			X	X	X	X
RBS 2					X		X			X
VTS 1	X			X		X	X	X		X
VTS 2		X	X				X	X	X	X
IOS	X			X			X		X	X

NOTES:

1. TWD at RBS and VTS autotracks 2-2-2.3 kmc and 400 mc signals.
2. TM-1B at IOS autotracks 400 mc and UHF signals.
TM-1B at RBS autotracks VHF and 400 mc signals.
TM-1B at VTS autotracks VHF signals.
3. All DOR's autotrack VHF signals.
4. VHF equipment necessary for supporting FM/FM and PCM type telemetry will be at the FM/FM Ground Station.

Figure 5. Augmented Tracking Stations Equipment Configurations

signal to drive the antenna positioning servos. Pre-amplifiers at the antenna, with 22-db gain, permit location of the VHF receivers at some distance from the antenna without appreciable deterioration of signal quality. The tracking accuracy varies between 0.12 degree at a 1-degree-per-second rate and 0.75 degree at a 6-degree-per-second rate. The antenna can be remotely positioned by the Slave Data Bus; pointing information is derived from another antenna or from acquisition data from the STC. Tracking accuracy in the Slave mode of operation is 2 degrees.

2.2.1.5 Disc-On-Rod (DOR) Antenna. The DOR Antenna is a VHF, passive, telemetry receiving system. It consists of four slow-wave, disc-on-rod structures, with a ground plane mounted on a synchro-driven, gimballed pedestal. It has a 21-db gain over the design frequency range of 225 to 260 mc. It has a beam width of approximately 14 degrees. It uses the interferometer method of angle determination and has an angular accuracy of 0.5 degree in both azimuth and elevation. The antenna can be manually positioned, can automatically track VHF signals, or can be slaved to synchro data from other antenna systems or acquisition information from the STC via the slave data bus. Signal sensitivity is in the range of -113 to -120 dbm. The system has self-contained amplifiers to develop the error signals used to drive the azimuth and elevation servos. The Telemetry signal is passed on, undetected, to external telemetry receivers in the FM/FM Ground Station.

2.2.1.6 Tri-Helix Antenna. This is a VHF, passive, telemetry receiving system. It consists of a three-element helical array on a hexagonal ground plane, which is mounted on a rotatable base. It has a 15-db gain over the design frequency range of 235 to 265 mc. It has a beam width of approximately 20 degrees and an angular accuracy of about 10 degrees. It can be manually operated to assist in initial acquisition of satellite VHF signals by supplying rough azimuth and elevation information. Its broad beam width does not require highly accurate acquisition data. It may be driven by the slave data bus, using acquisition data originating at the STC, or from data developed by more accurate antenna systems, such as Verlor or TLM-18. The pre-amplifiers used give an additional gain of 20 db and multicouplers allow up to six receivers to be connected to the same pre-amplifier channel.

2.2.2 Telemetry, Tracking, and Command Subsystems. The three subsystems described below have two important functions. On the one hand, they receive data from the satellite in the form of outputs from the Antenna subsystems and process it into a format that is usable to the Data Processing subsystem. On the other hand, acquisition data and commands from the STA via the Data Processing subsystem must be acted upon and put into a form suitable for transmission to the satellite by the Antenna subsystems.

Flexibility in the use of the station equipment is made possible by the use of two manual patching terminals--the Station Patch Board and the Cross Connect Panel. The Station Patch Board (SPB) interconnects the Telemetry Tracking, and Command subsystems with the Antenna subsystems. In addition to the regular control-circuit patching facilities, the SPB has coaxial switches for connecting radio-frequency lines from the FM/FM ground stations to the Antenna subsystems. The Cross Connect Panel (CCP) interconnects the Telemetry, Tracking, and Command subsystems to the Data Processing subsystem. The actual interfaces for the CCP are the TDP and IOB on one side, interconnecting with the T&C and TLM data-processing computers on the other side.

It is by means of these two patching terminals that the configurations of the dual tracking stations are determined. The configuration is usually selected by the STC and sent to the tracking stations in the prepass message. Emergency reconfigurations and last minute changes are readily accomplished because of the flexibility inherent in the patching terminals.

2.2.2.1 FM/FM Ground Station. The FM/FM Ground Station processes and records VHF telemetry data from the Telemetry Antenna Subsystem. There are 5 VHF receivers, including one spare, which accept inputs in the 215-to-260-mc band or at a 5-mc predetection IF frequency from an external VHF receiver. The composite video output of the receivers (100 cps to 125 kc) is recorded on magnetic tape for permanent record of all FM/FM telemetry data received. The subsystem has one 18-channel subcarrier discriminator (SCD) group for converting subcarrier channels into continuous telemetry analog outputs. In addition there are two 30-channel, pulse-amplitude-modulated (PAM) demultiplexers to demultiplex a total of 60 commutated points of the NRZ, GERZ or IRIG standard types. Up to a total of 64 selected analog outputs, continuous and demultiplexed, are sent to the telemetry data processor for conversion into digital form. The telemetry data flow is described more fully in Section 4.0 and a simplified block diagram of the FM/FM Ground Station is shown in Figure 10. Greater detail of the equipment and functions are given in References 3 and 16. The major functional components are listed below.

1. Two VHF Multicouplers.
2. Five VHF Telemetry Receivers.

3. Two Spectrum Display Units.
4. One 326⁴ Pin Master Patch Panel.
5. One 40-Position RF Patch Panel.
6. Two Seven-Channel Magnetic Tape Recorder/Reproducer Systems.
7. One 18-Channel Subcarrier Discriminator System.
8. Two 90-Channel Decommulator Systems with 30 Selectable Outputs.
9. Two 36-Channel Optical Oscillographic Recorder Systems.
10. One Band Switching Discriminator.
11. Three 8-Channel Pen (heated stylus) Oscillographic Recorders.
12. Five 18-Channel Analog/Digital Line Driver Amplifiers.
13. One Monitoring Equipment.
14. One Operational Alignment Equipment.
15. One Auxiliary Support Equipment.

2.2.2.2 PCM Ground Station. The PCM Ground Station functions as intermediate processing equipment between the telemetry receivers and the Telemetry Data Processor. It converts the serial, 3-level, pulse-code-modulated (PCM) data from the receiver frequency-discriminator output into parallel binary data words that are compatible with the Data Processing subsystem. The detected signal from the frequency discriminators is passed through a 30-kc filter to remove other telemetry data carried on a 70-kc subcarrier. The filter output is then fed to the input of the PCM converter. The PCM converter converts the 3-level signal into 2-level form and performs a noise rejection operation. The converted data are placed in intermediate storage to allow bi-directional entry. This is necessary because, on some programs, the PCM data are recorded on a vehicle-borne magnetic-tape system, and playback may be in either forward or reverse direction. The PCM data may be received, therefore, in either a forward or backward format.

For off-line data processing, the 3-level PCM data is used to modulate a voltage-controlled oscillator to provide a frequency modulated 70-kc carrier for recording on magnetic tape. The tape may then be played back through a 70-kc subcarrier discriminator to recover the 3-level PCM signal train, which may then be sent through the PCM converter for processing.

2.2.2.3 GP-1 Ground Station. The General Purpose PAM Ground Station (PAM-GP1) has been designed to receive a frequency-modulated PAM input signal from ground-based telemetry-receiving equipment and to provide digital output data. In addition, demultiplexing and analog outputs are provided for various users. This equipment can be programmed to handle various PAM formats by a main Program Board. It is capable of recording all received information on an appropriate wideband magnetic-tape recorder, such as the Ampex FR 700, and of reproducing this recorded information for off-line processing. A digital tape recorder, provided for backup capability, can record received information and reproduce this information for off-line processing. This recorder also makes it possible to check the input/output transfer performance of the PAM-GP1. The Ground Station is also capable of normalizing all PAM data; i.e., by making use of the calibrate information in the pulse train, the data information is normalized to the correct relative value, regardless of amplifier gain drift, r-f deviation drift, or initial system setup inaccuracies, within a correction range of ± 30 percent.

This equipment, of modular construction for the most part and subject to programming is made up of 19 functional units. These units are not necessarily physical entities, but may be composed of certain modules or groups of modules, the arrangements of which may change from one program to another. The PAM-GP1 Ground Station is composed of the following major functional components, which are housed in seven 4-inch relay racks:

1. Video Circuits.
2. Clock and Raw Sync Separator.
3. Multiphase Clock Generator.
4. Frame Sequencer.
5. Subframe Sequencer.
6. Frame Sync Logic.
7. Subframe Sync Logic.
8. Automatic Gain Control.
9. Digitizer.
10. Output Buffer.
11. Digital Record Electronics.
12. Digital Reproduce Electronics.

13. Analog Circuits.
14. Patch Panel.
15. Power Supplier and Interlock.
16. Digital Tape Recorder.
17. Wideband Tape Recorder.
18. R-F Detectors and Subcarrier Discriminators.
19. Signal Simulator.

The Ground Station performs these main functions:

1. Accepts input data in the form of a 5-mc frequency-modulated carrier.
2. Accepts input data in the form of a 30-mc frequency-modulated carrier.
3. Provides the capability of recording, on magnetic tape, the input data described in 1 and 2 above.
4. Allows for the capability of detecting the frequency modulation of the input signals described in 1 and 2 above.
5. Allows for the additional capability of detecting frequency-modulated subcarriers in systems utilizing PAM-FM-FM.
6. Provides the capability of supplying composite PAM video, PAM clock, PAM frame sync, and PAM block sync to display equipment.
7. Provides seven channels of smoothed (interpolation filtered) analog outputs, which may be programmed to any desired channel.
8. Provides a minimum of eight channels of sample-and-hold analog outputs, which may be programmed to any desired channel.
9. Provides the capability of performing the internal functions required of a General Purpose Sync Separator and Digitizer.

The equipment accepts a serial PAM pulse train at a data-sampling rate ranging from 500 cps to 40 kc. It can process a maximum of 256 high-frequency channels. Four of these high-frequency channels may be asynchronously

subcommutated to a maximum of 128 low-frequency channels; however, additional channels may be subcommutated provided they are synchronized with one or more of the asynchronous channels.

Seven smoothed analog outputs are provided. These signals are generated by demultiplexing the PAM pulse train, passing the resulting PAM pulses through an interpolation filter and then through an amplifier for amplification. The choice of the channels to be demultiplexed is performed on the Program Board.

Eight sample-and-hold outputs are also provided. The choice of channels to be sampled and held is performed on the Program Board. Each sample-and-hold circuit samples the level of a particular data channel over a brief interval of time and then, through memory, retains this level until a new sample is made available. Upon the arrival of a keying pulse that initiates another sample, the output of the sample-and-hold circuit changes to the new data level and remains at that level until a new sample is provided.

2.2.2.4 400-mc Receiving/Commanding Equipment. The 400-mc equipment is used with the TIM-18 or T&D antenna subsystems to enable them to actively track vehicles having 400-mc transponders. The feed systems of these antennas are modified to accommodate the new frequency band. The equipment can furnish error signals to null the antenna-positioning servos and provide auto-track capability for the antenna at 400 mc. The doppler shift frequency can be extracted from the received signal to obtain range-rate information. The existing precision synchros and encoders geared to the antenna axes provide antenna angle data. The equipment can accept telemetry data from 400-mc, vehicle-borne transmitters and can be used for commanding with vehicles carrying 375-mc receivers. The modifications to the antennas do not affect their capability to function at their original design frequency.

2.2.3 Data Processing Subsystem. The Data Processing subsystem interfaces with the Telemetry, Tracking, and Command subsystems through the Cross Connect Panel. Direct contact with the SIC is maintained via the 1200-bps data lines. The principal functions of the Data Processing subsystem are the following:

1. Accepts predicted acquisition and ephemeris data from the SIC and converts this information to continuous antenna-position data for the tracking-station antenna systems.
2. Provides antenna-pointing data to the radar-tracking-subsystem antenna drives and telemetry-subsystem antenna drives, via the appropriate slaving busses.
3. Accepts tracking data from the radar-tracking subsystem and provides tracking data for transmission to the SIC.

4. Accepts digital antenna position data from the telemetry-antenna subsystem and provides data for transmission to the STC.
5. Provides and accepts status and control data to and from the Station Operator's Console (SOC). Provides digital-command data for modulating the radar, command transmitter, and telemetry antennas command-modulation equipment, and provides analog-command data to the radar-modulation equipment.
6. Processes telemetry data from the telemetry subsystems in real time and postpass.
7. Performs control and monitoring functions for the Checkout Subsystem.
8. Provides for generating the ETA and ETT in time displays on the SOC.
9. Records selected data.
10. Provides time comparison between vehicle and system time and provides this to the STC.

Main components of the Data Processing subsystem are as follows:

1. Tracking and Command (T&C) Computer Subsystem.
2. Telemetry (TLM) Computer Subsystem.
3. Input/Output Buffer.
4. Telemetry Data Processor.
5. Command Logic Equipment.
6. Station Operator's Console.

2.2.3.1 Tracking and Command Computer Subsystem (T&C). The T&C computer complex consists of one each CDC 160A Computer, CDC 169 External Computer Memory, CDC 166 Buffered Line Printer, CDC 163-4 Magnetic Tape Unit, and CDC 161 Typewriter. The computer has one set of programs for real-time (RT) operations and one set for non-real-time (NRT) operations. The RT programs operate when the tracking station is servicing a vehicle. NRT programs operate in the period between active servicing of vehicles.

The following tracking and commanding functions are performed during RT:

1. The RT Program uses standardized predicted acquisition data messages (in station azimuth, elevation, and range coordinates) to provide slaving data to an acquisition synch converter for use by the Antenna subsystem. Each pointing data message contains header data and data-point sets (azimuth, elevation, and range) spaced at a uniform Δ_t between sets. ($\Delta_t = 2n$ seconds, where $0 \leq n \leq 6$). The RT program interpolates the data to 20 sps and supplies it to the acquisition synch converter for use under SOC control.
2. The RT program provides and accepts command data and status to and from the Station Operator's Console (SOC), commands and command data from the STC, provides digital-command capability, records significant events pertaining to analog and digital commanding, and reports commanding operational status to the STC. Provisions will be made to accept command verification from the FM/FM Ground Station (or the Telemetry Data Processor) and echo signals from the CLE, when available.
3. The RT program reads data on azimuth, elevation, transverse, range, range rate, control, and status (as supplied by the antennas selected) through a digital data link, from the antennas once each second for history records, and formats the selected information for transmission to STC at a normal rate (or rate selected by STC prepass or real time).
4. The RT program provides and accepts status and control data to and from STC, the Station Operator's Console, and other tracking station subsystems.
5. The RT program accepts system time and vehicle system time word inputs and provides timing and vehicle identification display outputs. System time will be accepted from the ground timing equipment and used in timing displays or for time-tagging acquisition messages and command messages. Vehicle system time and ground vehicle time offset shall be accepted from the ground telemetry subsystem and recorded and transmitted to STC, as required.
6. The RT program provides the capability for recording a history of selected data. The history subprograms provides the capability to record and play back chronological records of command actions (analog or digital) including initiations, transmission, echo-check data, and vehicle reactions; tracking data; raw time-tagged telemetry; and other data, as dictated by operation

requirements such as timing and SOC actions. This function is also required of the telemetry operational program.

The following tracking and commanding functions are performed during NRT:

1. The NRT program accepts new vehicle specifications, commanding and pointing data from STC, and merges them with operation tapes already on hand at the tracking station.
2. If required, the NRT program enters a Playback mode, in which history tapes are made available to the STC or for readout at the station.
3. The NRT program performs schedule printouts, as required, for station operation.
4. In some cases, the NRT program coordinates those SOC functions involving system time, ETA, ETT, etc.
5. The NRT program coordinates the checkout programs, including daily and prepass checkouts.
6. The NRT program arranges the real-time program in the specific configuration determined by data sent from the STC.
7. The NRT program accomplishes the transition from non-real-time to real-time operation.

2.2.3.2 Telemetry Computer Subsystem (TLM). The TLM Computer subsystem has the same basic equipment as the T&C computer complex; only the programming is different. The TLM programs are divided into an RT set and an NRT set, as are the T&C programs.

The following telemetry functions are performed during RT:

One telemetry data stream is accepted, time tagged, and recorded. Some of the data are processed for local and STC real-time use and postpass analysis. The telemetry program formats and compresses the data from selected channels in real time, sends selected outputs to the STC, and locates command verification data. Compression modes will be provided as options in the computer program. The telemetry points selected and the parameters of a processing algorithm may be changed without loss of data. The telemetry mode may also be changed during a pass but some data are lost during the change over.

During NRT, the following telemetry functions are performed:

1. New modes are accepted for telemetry compression.

direction, specifying which mode is to be used on particular vehicle passes, and merged with data already on the magnetic operations tapes at the site.

2. Scheduled printouts are produced, as necessary.
3. Transition from non-real time to real time is performed.
4. The capability exists to read and process raw telemetry data from a digital history tape.

2.2.3.3 Input/Output Buffer (IOB). The IOB provides for computer-programmable input and output of digital data, in real time, to and from a CDC 160A computer. The computer program sets the rate of input/output for each datum and selects the input/output device and function at the correct time by the use of function-select codes. Computer interrupts are used to trigger input/output functions of the computer program.

The IOB interrupts the computer by means of interrupt 10 for the Command Logic Equipment (CLE) functions, which have the highest priority of any interrupt in the T&C 160A. The IOB uses interrupt 40 to interrupt the computer at a 20 pps rate for timing inputs and outputs from the other equipment. Finally, the IOB uses interrupt 30 for digital data link equipment inputs.

The IOB transfers output data to the following equipment under computer control:

1. CDC-160A Computer.
2. Station Operator Console.
3. Acquisition Servos for Slave Data Bus.
4. Command Logic Equipment.
5. Check-out Subsystem.

It transfers input data from the following equipment under computer control:

1. CDC-160A Computer.
2. Selected Antenna Position Encoders (Via Computer Digital Terminals 1 and 2).
3. System and Vehicle Time Word and Offset.

4. Station Operator Console.
5. Command Logic Equipment.
6. Checkout Subsystem.

2.2.3.4 Telemetry Data Processor (TDP). The TDP interfaces between the telemetry subsystems and the telemetry 160A computer. It accepts vehicle telemetry data from the GP-1(a), GP-1(b), FM/FM, and PCM telemetry subsystems. The TDP can select for input the system-time code word (STCW) and a 12-bit input control word. With certain telemetry systems, the TDP can send a 12-bit output (control) word to the station patchboard for transmission to the IOB. This word is used in communicating the vehicle command verification to the commanding subprogram in real time.

The GP-1 systems will input one 12-bit word/telemetry value to the TDP. The FM/FM system will input up to 64 channels of analog values to the TDP; a manually programmable plugboard permits sampling of up to 64 channels (at a maximum rate of 25 kc) and digitizing of sampled data for the 160A. The PCM system will provide one or ten unsynchronized data bits/12-bit word(s) to the 160A. One pps is marked t_0 in all telemetry data streams. A receiver phase-loop, lock-on bit is provided in the twelfth bit.

The 160A can select any one of the TDP inputs or outputs by programmed execution of the appropriate function select codes. The TDP includes a scanner, a digitizer, and a computer select unit. The scanner will be capable of sampling the input from each subcarrier discriminator or decommutator in the FM/FM ground telemetry subsystem (or a maximum of 64 similar sources) at a minimum individual rate of 5 cps and a maximum combined rate of 25 kc. The selectable rates and sequence of sampling the various sources will be determined by a programmed patchboard.

2.2.3.5 Command Logic Equipment (CLE). The CLE processes inputs from the Station Operator's Console (SOC) and the T&C computer in order to control the transmission of analog and digital commands to satellites via the command transmission facilities of the antenna subsystems. The CLE has storage buffers, logic circuitry, and function counters. It furnishes outputs to various external equipments in the form of relay closures. It transforms parallel digital commands from the computer to serial form for transmission to the satellite.

For "analog" commands, the CLE translates the command number selected by the SOC (two BCI digits) into two outputs corresponding to one of 15 commands. When the "Transmit" signal is received from the SOC, these outputs are gated to pick up two out of six relays and to hold them in an operate condition for one second. These relay closures are used to tone-modulate the radio-frequency carrier that carries the command information to the satellite. A

command counter is stepped once for each "transmit" and the number of the command transmitted is indicated on the SOC. Approximately 300 milliseconds after the command relays close, a command echo check is returned from the transmitter. This echo check consists of two out of six relay closures, held closed for one second. The CLE compares the echo-check data with the command previously transmitted. If not in agreement, the Command Error indicator on the SOC is turned on, and further commanding is inhibited until the Command Error indication has been cleared by the "Error Override" pushbutton on the SOC. Also, about 300 milliseconds after transmission, a command verification from the satellite is returned to the CLE via the FM/FM ground station. This consists of two out of six relay closures, held closed for one second, which are compared with the transmitted command relay closures. If they agree, the verification indicator on the SOC is turned on and a verification counter is stepped on count.

When the SOC goes into the Repetitive Transmit mode, the CLE retransmits the same command once every two seconds until the "Stop Repetitive" push button is depressed or until the total number of commands transmitted equals the repetitive number selected on the SOC. The CLE stops repetitive transmission if a command echo check error is received. When the "Error Override" push button is depressed on the SOC, the CLE resumes sending the repetitive commands. A count of successful repetitions made is furnished by the CLE for display at the SOC.

Digital command messages are furnished to the CLE from the T&C computer. The command mode, command number, reject level, and transmit order are transferred from the SOC to the T&C Computer via the CLE. The computer extracts from memory the command word corresponding to the command number and provides it to the CLE via the IOB, serially bit by bit, on a computer-interrupt basis. The rate of command-bit transfers from the computer to the CLE is primarily determined by the sync PRF of the command transmitter (the maximum rate being one kc), which also controls the command bit transmission rate from the CLE to the command transmitter.

Echo check data are returned from the command transmitter to the CLE, serially bit by bit, at the sync PRF. These data are sampled by the computer and compared in the computer with the original command in memory, in real time. An Echo Check error indication is made on the SOC.

A Command Verification indication (accept or reject) is returned to the CLE after completion of each command word transmission, and is made available to the SOC and the T&C computer via the IOB. The computer also monitors the verification inputs for the occurrence of spoofs, which also are displayed on the SOC and recorded by the computer.

The various modes of analog and digital commanding are explained in detail in Section 5.0, which also describes additional functions performed by CLE.

2.2.3.6 Station Operator's Console. The Station Operator's Console (SOC) is the central control point at the tracking station. It is here that the switches and displays used to monitor and control the tracking, telemetry, command, data handling, and other functions are located. There are 18 panels, arranged in functional groupings, so that three operators can work the console with a minimum of interference with each other (Figure 6). These operators are the Command Controller, the Antenna Controller, and the Shift Supervisor.

On the left side of the console is a group of panels involved with the Antenna subsystem (Figure 7). These are:

1. Signal Strength Panel - This panel has two meters, which display the strength of the tracking signals of the Radar Tracker and Telemetry Tracker. Four lighted displays indicate the operating mode of each tracker. For the Radar Tracker, these modes are Locked on, Slaved, Search, and Manual. For the Telemetry Tracker they are Auto Tracking, Slaved, Search, and Manual.
2. Range Panel - This panel has a large, circular dial, which shows the range in 20 n.m. increments out to 5100 n.m. The dial has two cursors: one indicates range from the Radar Tracker, and the other the range from the Computer Acquisition program.
3. Azimuth Panel - This panel has a large, circular 360° dial, which is divided into 2° increments. The dial has three cursors, which indicate azimuth derived from: (1) the Radar Tracker, (2) the Telemetry Tracker, and (3) the Computer Acquisition program.
4. Elevation Panel - This panel has a large, circular dial, which displays elevation in 2° increments from 90° at the top center of the dial down to -20° on each side. The dial is not calibrated full scale. The dial has three cursors, which display elevation as derived from the same three sources listed for the Azimuth Panel.
5. Antenna Control Panel - This panel has two sets of push buttons and one set of indicator lamps. One set of three push buttons is labeled "Directing Source" and offers three choices for selecting the source to drive the system sync slave bus: (1) "Computer", (2) "Radar Tracker", and (3) "Telemetry Tracker". The other set of four push buttons controls the starting and stopping of the acquisition program. When the "Computer Control" push button is depressed, the acquisition program is under the control of the T&C computer. When the "Manual Control" push button is depressed, along with the "Manual Start" or "Manual

1 April 1963

47
(Page 48 blank)

TM-1146/000/00

ANTENNA
CONTROLLER
SECTION

SHIFT
SUPERVISOR
SECTION

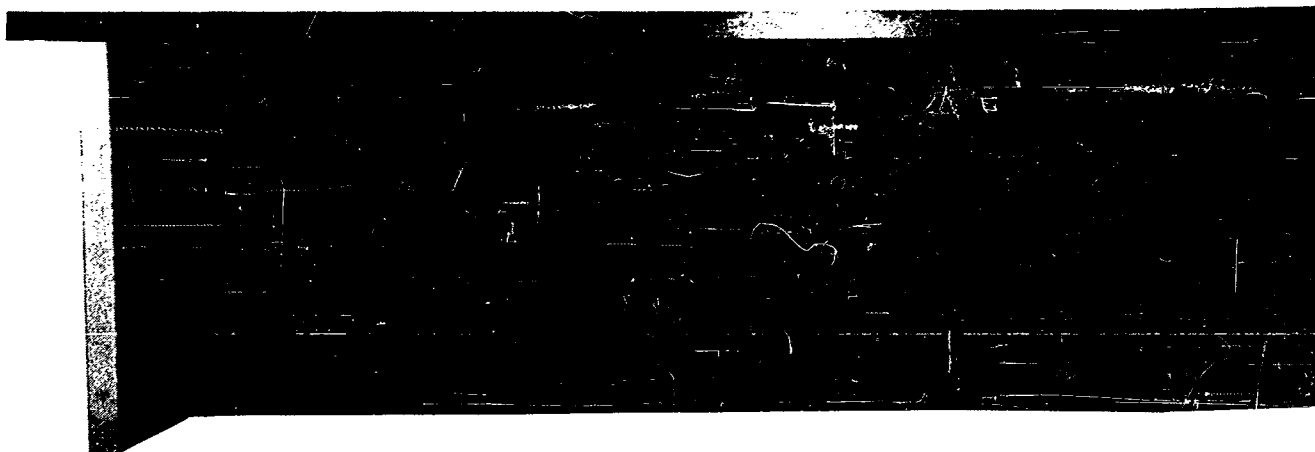
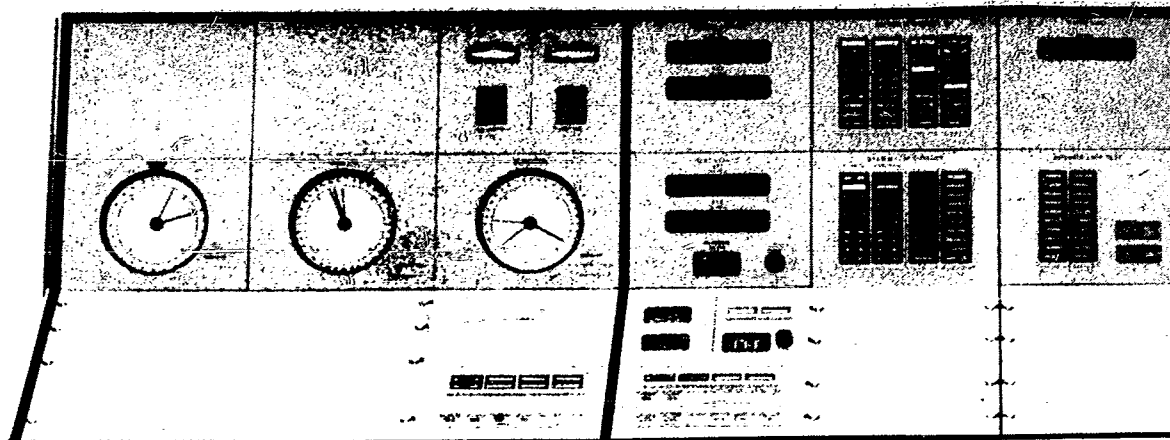

Figure 6. Station Operator's Console

1146/000/00

SHIFT
SUPERVISOR
SECTION

COMMAND
CONTROLLER
SECTION

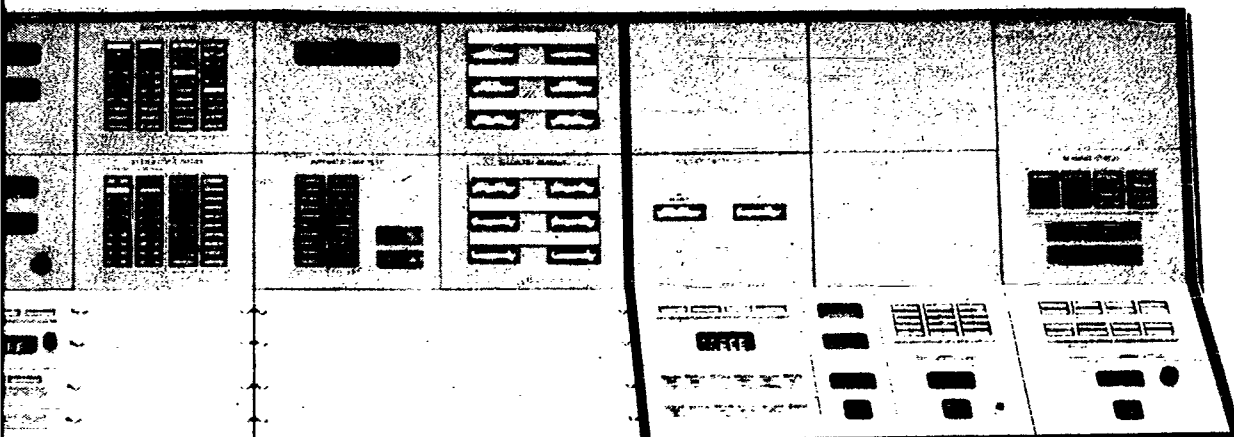

Figure 6. Station Operator's Console

2

1 April 1963

49
(Page 50 blank)

TM-1146/000/00

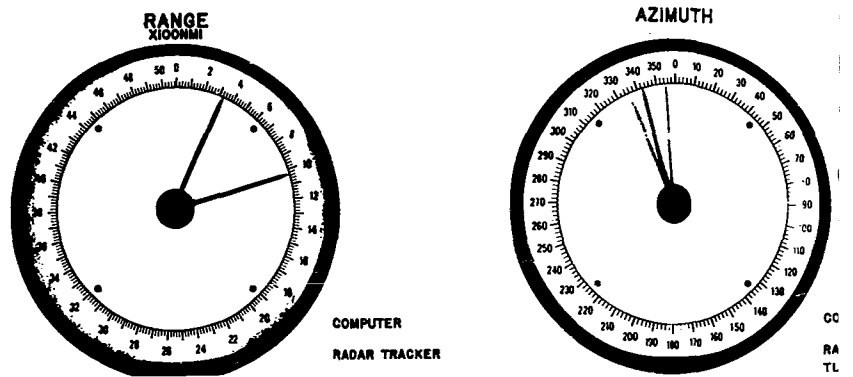

Figure 7. SOC--Antenna Controller S

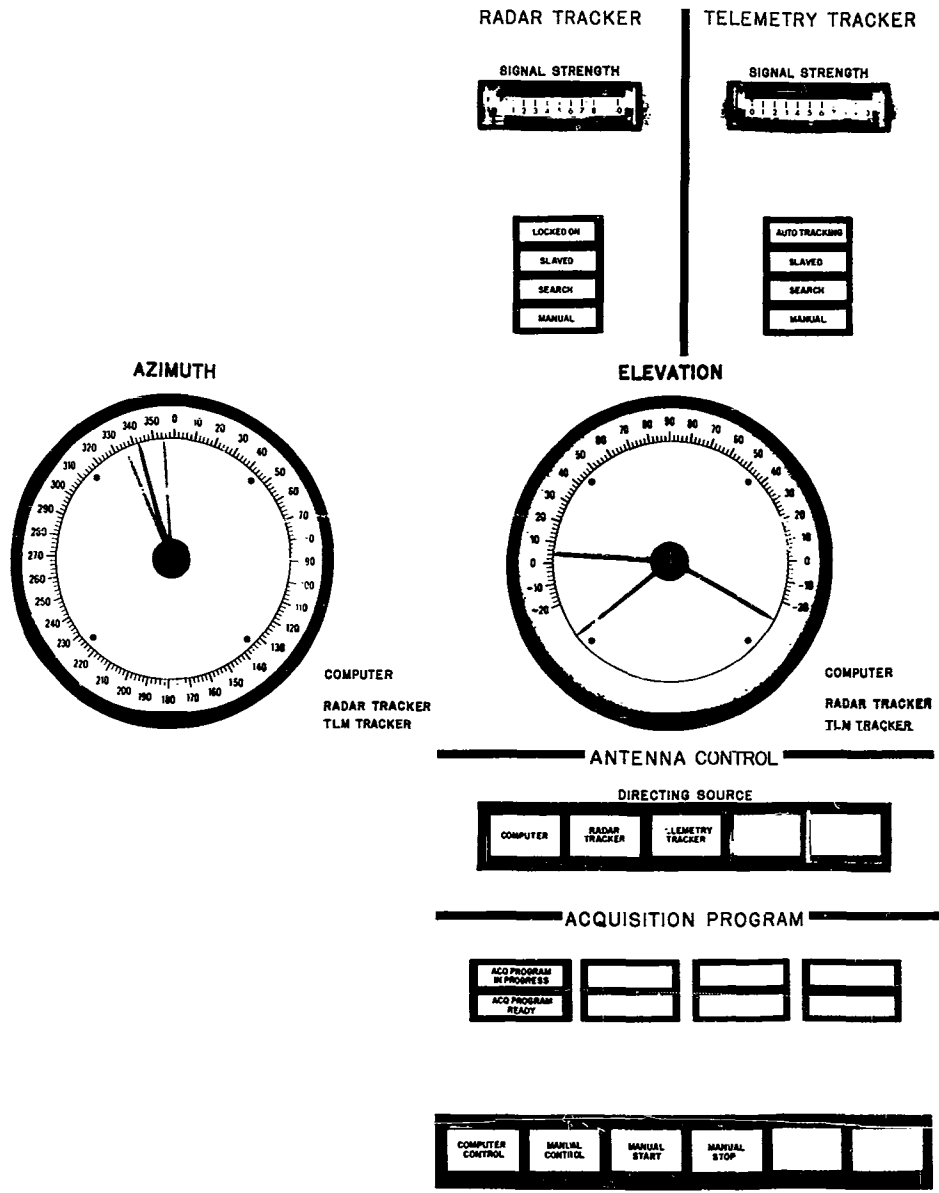

Figure 7. SOC--Antenna Controller Section

2

1 April 1963

51
(Page 52 blank)

TM-1146/000/00

STEPPER SWITCH POSITION

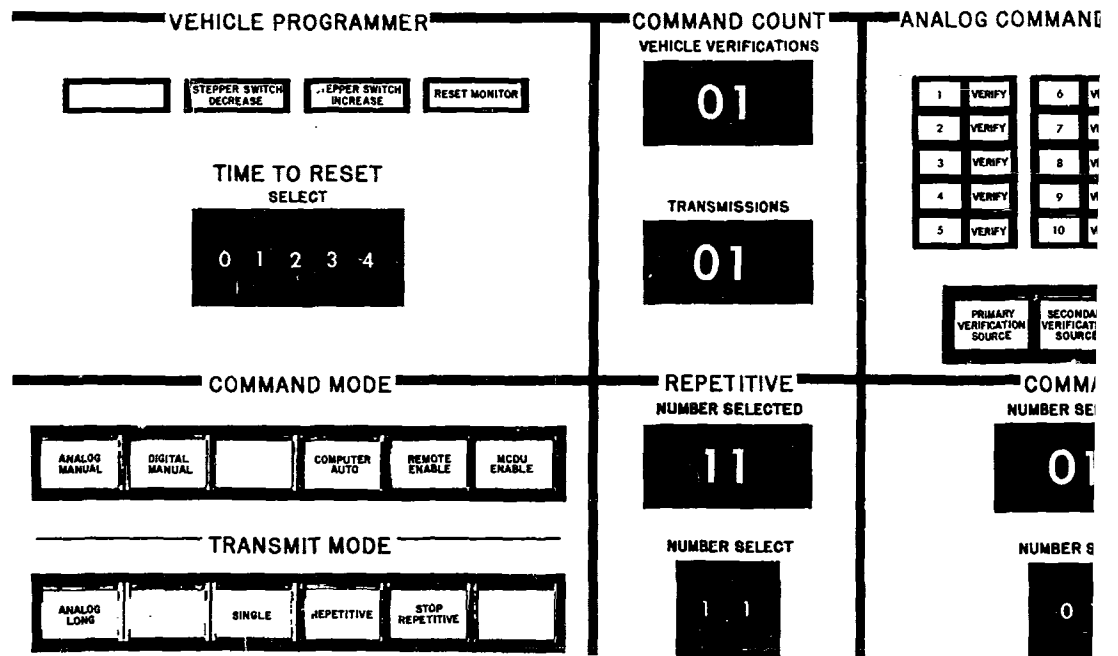

Figure 8. SOC--Command Controller

COMMAND STATUS

COMPUTER AUTO COMPLETE	REMOTE COMMAND COMPLETE	MCDU COMPLETE	
COMPUTER AUTO IN PROGRESS	REMOTE COMMAND IN PROGRESS		
COMPUTER AUTO READY	REMOTE COMMAND READY	MCDU READY	

COMPUTER AUTO STOP			

COMMAND COUNT
CLE VERIFICATIONS

01

TRANSMISSIONS

01

ANALOG COMMAND VERIFICATION

1 VERIFY	6 VERIFY	11 VERIFY
2 VERIFY	7 VERIFY	12 VERIFY
3 VERIFY	8 VERIFY	13 VERIFY
4 VERIFY	9 VERIFY	14 VERIFY
5 VERIFY	10 VERIFY	15 VERIFY

PRIMARY VERIFICATION SOURCE	SECONDARY VERIFICATION SOURCE	
-----------------------------	-------------------------------	--

COMMAND STATUS

RADAR TRACKER ANALOG MODE	DECOMM 1 SYNC OUT		
	DECOMM 2 SYNC OUT		

		REJECT LEVEL REACHED	
	COMMAND ERROR	COMMAND REJECT	SPOOF

	ERROR OVERRIDE		SPOOF RESET
--	----------------	--	-------------

REPETITIVE
NUMBER SELECTED

11

COMMAND
NUMBER SELECTED

01

REJECT

COUNT

01

COUNT CLEAR



NUMBER SELECT

11

NUMBER SELECT

01

TRANSMIT



LEVEL SELECT

01



Figure 8. SOC--Command Controller Section

Start" or "Manual Stop" push button, the acquisition program is under the control of the SOC operator. Two lighted displays indicate "Acquisition Program Ready" or "Acquisition Program in Progress".

On the right side of the SOC is a group of panels involved with the commanding and telemetry functions (Figure 8). These are:

1. Command Status Panel - This is actually two panels, one above the other, on the far right of the SOC. The upper panel has two switches and three banks of indicator lights. The two switches are "Computer Auto Stop," which stops the automatic sending of the commands by the computer, and "Computer Command Advance," which allows the command program to proceed when a "Command Reject" has been received or the reject level has been reached. One bank of indicators shows whether the computer automatic commanding program is "ready", "in progress", or "complete". Another bank shows the same three conditions for a command sequence from remote console. The third bank indicates whether the MCDU console is "ready" to transmit a command sequence or whether the command sequence is "complete".

The lower panel has two parts: (1) a "Command Status" part, which has two banks of indicators and a row of push button switches; (2) a "Reject" part, which has a digital select switch, a digital "Count" display, and a "Count Clear" push button switch. One bank has four indicators. There is an "Analog Command Coder" and a "Digital Command Coder" to show which type of command the selected Radar Tracker is prepared to send. The other two indicators light up if either the number 1 or number 2 decommutator drops out of synchronism. The second bank has seven indicators, as follows:

- a. "Verification Not Received" - Indicates that a command has been sent but that no verify or reject has been received from the vehicle.
- b. "Command Accept" - Indicates that the vehicle has accepted the last command and sent verification.
- c. "Command Error" - Indicates that an error was made in the transmission of the command.
- d. "Reject Level Reached" - Indicates that the number of rejections of a command by the vehicle has reached the preset level.
- e. "Command Reject" - Indicates that the last command sent has been rejected by the vehicle.

- f. "Improper Command" - Indicates that the vehicle has accepted an improper command.
- g. "Spoof" - Indicates that a false verification was received while the last command was being transmitted.

In the row of push button switches are: (1) "Manual Verify," which allows the command program to proceed when verification of the last command was not received from the vehicle and there was no "Command Error" or "Command Reject;" (2) "Error Override," which allows the command program to proceed when a "Command Error" and a "Command Accept" occur simultaneously; and (3) "Spoof Override," which resets the "Spoof" indicator.

On the "Reject" part of this panel, the digital select switch, "Level Select," has 100 positions, (0 - 99) which allows the operator to select any number up to 99 for which a command will be transmitted and rejected by the vehicle. There is a "Count" display, which indicates, in decimal digits, the number of times a command has been rejected. A "Count Clear" push button clears this indicator.

- 2. "Radar Command Panel" - This panel controls a number of functions and is divided into six groups of controls; these are:
 - a. "Vehicle Programmer" group - There are four displays pertinent to the Fairchild Timer Operation. Two indicators show whether the stepper switch in the vehicle is in the "Increase" or "Decrease" position. A third indicator, the "Reset Monitor," indicates whether the vehicle stepper switch may be reset. The fourth indicator is composed of five rotary drums, each of which has ten digital positions (0 - 9); this indicator is used to display the system time at which the reset command must be manually transmitted.
 - b. The next group is made up of two banks of push buttons: the "Command Mode" switches and the "Transmit Mode" switches. These set up the commanding options discussed in detail in Section 5.0. The Command modes are: Analog Manual, Digital Manual, Computer Auto, Remote Enable, and MCDU Enable. The Transmit modes are: Analog Long, Single, Repetitive, and Stop Repetitive.
 - c. The "Command Count" group has two 2-digit projection readout displays. One, the "Vehicle Verifications" display, shows the number of verifications received on the last command selected. The other display, the "Transmissions" readout,

shows the number of times the last selected command has been transmitted.

- d. The "Repetitive" group has a "Number Select" switch that has 100 positions (0 - 99) which allows the operator to select the number of times a command will be repeated with verification from the vehicle. It also has a 0-99 projection readout display, which indicates the number of repetitions of the command that have actually been made.
 - e. The "Analog Command Verification" group has two switches and 15 split-legend indicators. The switches are: (1) "Primary Verification Source," which selects the true analog output of the subcarrier discriminator for command verification. The 15 split-legend indicators show, in one half of the split legend, which of 15 possible analog commands have been transmitted and show, in the other half, the vehicle verification of that command.
 - f. The "Command" group has a "Number Select" control consisting of two rotary drums with ten positions (0 - 9) each, which allows the operator to select one of 99 commands stored in the T&C computer. A "Number Selected" display shows the number of the command or block transmitted. The "Transmit" push button, which initiates all command from the SOC, is also in this group.
3. "Telemetry Readout" Panels - There are two panels, each having six meters with a full-scale calibration of 0 to 10, in increments of 0.2. Selected telemetry points in analog form can be displayed on these meters. Above each meter is fastened a piece of white formica, on which the identity of the telemetry point selected may be written in with grease pencil.
 4. "Stepper Switch Position" Panel - There are two meters on this panel, which indicate the positions of the first and second stepper switches in the Fairchild Timer in the vehicle. The "10 Seconds" display indicates the position of the first stepper switch and the "110 Seconds" display indicates the position of the second stepper switch.

Grouped in the center of the SOC are the seven remaining panels, which control the functions that would normally be the responsibility of the Shift Supervisor (Figure 9). Here are located such functions as vehicle selection and assignment, equipment status, system configuration, system time and testing facilities. These seven panels are:

1 April 1963

57
(Page 58 blank)

TM-1146/000/00

CURRENT VEHICLE
ETT
SECONDS

00900

ETA
SECONDS

00083

NEXT VEHICLE
ETT
SECONDS

00965

ETA
SECONDS

00396

NUMBER
SELECT

0 1 2 3

ENTER

STATION BOARD
NUMBER

09

CURRENT VEHICLE
NUMBER

COMPUTER
VERIFIED

TELEMETRY BOARD
NUMBER

03

SELECT

0 1 2 3

ENTER

DATA TRANSMIT

TRACKING DATA TRANSMIT COMPLETE

TELEMETRY DATA TRANSMIT COMPLETE

TRACKING DATA TRANSMIT

TELEMETRY DATA TRANSMIT

LAMP TEST

STATION STATUS

STATUS INDICATORS

SWITCH INDICATORS

PREPARE

TEST

READY

EQUIPMENT STATUS

TLM COMPUTER NOT READY	TLM COMPUTER READY	RADAR TRACKER NOT READY	RADAR TRACKER READY
COMMAND CMPTR NOT READY	COMMAND CMPTR READY	TLM TRACKER NOT READY	TLM TRACKER READY
COMMAND LOGIC NOT READY	COMMAND LOGIC READY	FM/FM NOT READY	FM/FM READY
TOP NOT READY	TOP READY	PAN GRD STA NOT READY	PAN GRD STA READY
CCC1 NOT READY	CCC1 READY	FM/MS NOT READY	FM/MS READY
CCC2 NOT READY	CCC2 READY		
TOP NOT READY	TOP READY		

SYSTEM CONFIGURATION

TELEMETRY	COND/TRACK		
TOP1	COMMAND LOGIC	ROR TRACKER 1	
TOP2		ROR TRACKER 2	
COMPUTER 1	COMPUTER 1	TLM TRACKER 1	
COMPUTER 2	COMPUTER 2	TLM TRACKER 2	
COMPUTER 3	COMPUTER 3	TLM TRACKER 3	
COMPUTER 4	COMPUTER 4	FM/FM1	
CCC1A	CCC1A	FM/FM2	
CCC1B	CCC1B	PAN GRD STA 1	
CCC2A	CCC2A	PAN GRD STA 2	
CCC2B	CCC2B		



Figure 9. SOC--Shift Super

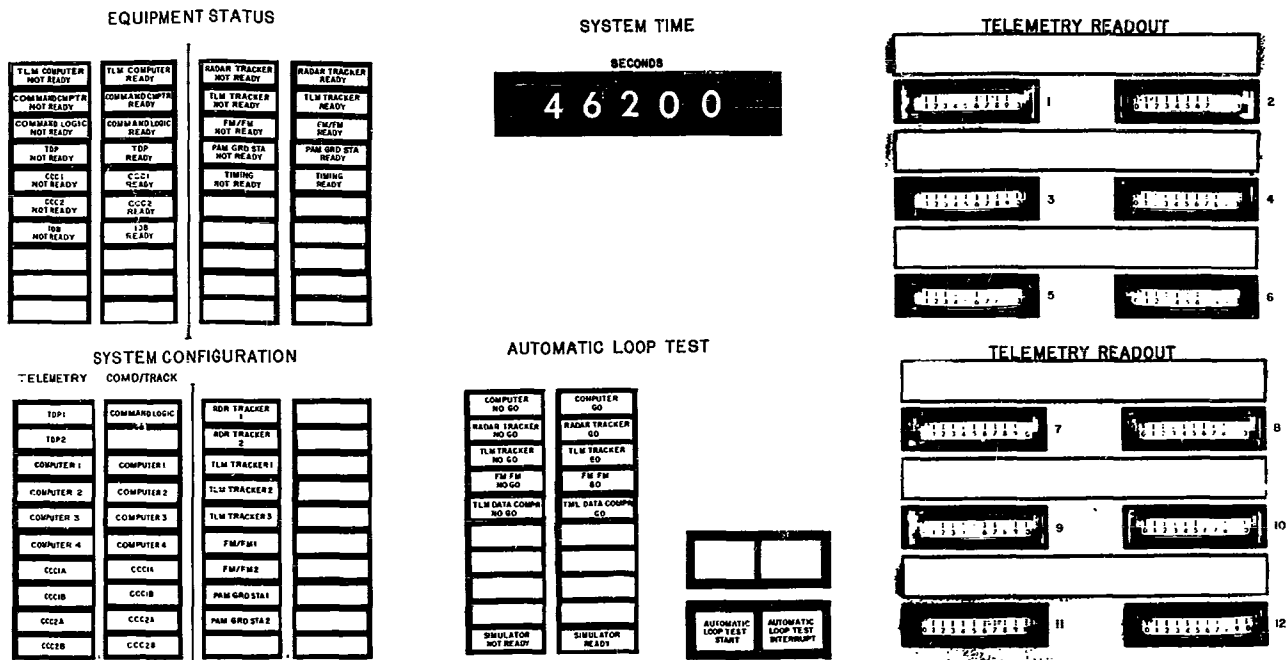

Figure 9. SOC--Shift Supervisor Section



2. Current Vehicle Panel - This panel has two 5-projection readout displays which show the total seconds remaining until time of acquisition ("ETA") and the total seconds remaining to track ("ETP") the current vehicle. These displays are driven by the T&C computer.
3. Next Vehicle Panel - This panel has the same "ETA" and "ETP" displays as the Current Vehicle panel, but they are used for the next vehicle. The next vehicle number is selected by a "Number Select" control, which has four 10-position rotary drums and is located on this panel. The vehicle number is entered into the T&C computer via the IOB by means of an "Enter" push button, also located on this panel.
4. Equipment Status Panel - This panel has 12 pairs of lighted indicators for the following 12 station subsystems. These status indicators are furnished to the SOC by manual switch closures made at the various equipments.
 - a. Telemetry Computer.
 - b. Tracking and Command Computer.
 - c. Command Logic.
 - d. Telemetry Data Processor.
 - e. Computer Communications Converter # 1.
 - f. Computer Communications Converter # 2.
 - g. Input/Output Buffer.
 - h. Radar Tracker.
 - i. Telemetry Tracker.
 - j. FM/FM Ground Station.
 - k. PAM Ground Station.
 - l. Timing.
5. System Time Panel - System time is displayed on 5 projection readout units, which indicate the system time in total number of seconds accumulated in a 24-hour day to the nearest second.

6. System Configuration Panel - This panel has 28 indicators, which operate from inputs derived from the Station Program Board and the Cross Connect Panel. The indicators show which equipments are assigned to the tracking station equipment complex under control of the SOC. The remaining equipments will, of course, be assigned to the other SOC or held as spare. Thus, for the station telemetry configuration, there are indicators for two TDP's, four 160A computers and four CCC's (each half of a CCC is listed separately because the TLM computer could be assigned to either half). For the command and tracking configuration, a similar set of indicators exists, showing computers CCC's and CLE's. Other equipments listed are Radar Trackers 1 and 2; TLM Trackers 1, 2 and 3; FM/FM Ground Station 1 and 2; and PAM Ground Stations 1 and 2.
7. Automatic Loop Test Panel - This panel has two switches: one starts the automatic loop test and the other interrupts it. There are five pairs of "Go" and "No Go" indicators, one pair each for the computer, radar tracker, TLM tracker, FM/FM Ground Station, and the TDP. A sixth pair of indicators shows whether the simulator is "Ready" or "Not Ready".

Most of the panels discussed above have spare indicators and switches to allow for additions and reconfigurations.

2.3 COMMUNICATIONS EQUIPMENT

Certain equipments are associated with the 1200-bps data lines and are common to the STC and all the tracking stations. These equipments are:

1. Computer Communications Converter.
2. Modulator and Demodulator Terminal Equipment (MODEM).
3. KG-13 Cryptographic Machine.
4. Automatic Resynchronizing Equipment (Auto-Resync).

2.3.1 Computer Communications Converter (CCC). The CCC is the interface device that makes the 160A computer parallel, input/output, word format compatible with the serial input/output requirements of the 1200-bps data-line terminal equipment. The CCC is used at both ends of the 1200-bps data lines. At the STC, it interfaces with the 160A Bird Buffer. At the tracking station, it handles data to and from both the T&C computer and the Telemetry computer, interchanging a word with each computer alternately. Just as the 1200-bps line has a full duplex capability, so does the CCC; its sending and receiving functions are completely independent.

The CCC has four modes of operation: (1) Sending, (2) Receiving, (3) No Data, and (4) Resync. Only the Resync mode excludes the other modes.

In the Sending mode, when a computer has a word to transmit to the other station, it sends a transmit request to the CCC, followed by a 12-bit data word. The CCC also provides an interrupt to the computer at the end of each data transmission cycle, which may be utilized by the computer to assure proper timing of data transfers to or from the CCC. Four control bits are added to the word for identification of the source and destination of the word, for parity check, and for synchronization. The resultant 16-bit word is then passed to the 1200-bps line terminal equipment. An internally generated resync word is sent after each 128 words.

In the Receiving mode, the 16-bit word is stripped of its 4 control bits and placed serially into the output register, where it is ready for parallel transmission to the proper computer. The CCC furnishes an interrupt to the computer which will accept the word.

The No Data mode is entered when there is no word to be transmitted by a computer. Where a CCC is interfaced with two computers, and one computer has no word to transmit, the CCC accepts alternate words from one computer, after sending an interrupt to the non-transmitting computer each time its turn to transfer a word comes up. When there is no word to be transferred from either computer, the No Data mode is entered and the CCC generates an internal word for transmission to the CCC on the other end of the line. This self-generated word is used to keep the system in synchronism, and is not transferred beyond the CCC.

The Resync mode is entered when the system drops out of synchronism. In this condition, sync data words are exchanged by the two CCC's at each end of the line. The 128-word counters are reset to zero when synchronism is reestablished and the CCC's enter one of the other three modes.

2.3.2 Modulator and Demodulator Terminal Equipment (MODEM). The inter-Station Communication Modulator and Demodulator (MODEM) Terminal Equipment is designed to interface the 1200-bit data lines to the high-speed cryptographic equipment (KG-13). Each duplex line that is used to communicate with the STA will require a MODEM at each end of the line.

The MODEM is used at the transmitting terminal to transform the input digital data into a form suitable for transmission over voice-communication circuits. At the receiving terminal, the MODEM restores the information to its original digital form. In addition, the MODEM supplies a bit-rate timing pulse to the KG-13, Auto-Resync, and Computer Communications Converter (CCG) equipment, and is capable of operating between 0 and 50,000 bits per second.

2.3.3 KG-13 Cryptographic Machine. The KG-13 is a cryptographic machine that is used on the 1200-bps line. The KW-26 cryptographic unit will be standard equipment for the 100-word-per-minute teletype line. The KW-26 does not require the MODEM to interface it with the teletype transmission lines.

The word length that the KG-13 can handle is limited to 16 bits. A word length of 16 bits has been selected as a standard transmission word length for the Augmented System. Of these 16 bits, only 12 can be used to transmit data. The other 4 bits are used by the Inter-Station Communication System as control bits.

2.3.4 Automatic Resynchronizing Equipment (Auto-Resync). The Auto-Resync Equipment is part of the Inter-Station Communication System. It is used to check, sense, and perform the commands and routines necessary for maintaining the integrity of the transmitting and receiving cryptographic equipment. This equipment interfaces with the KG-13 and the CCC, via the Communication Data Select and Cross Connect Unit (CDSCCU) and MODEM.

Normal use of the KG-13 requires manual intervention to place the equipment back on the line if, for some reason, improper line response has been detected. The amount of time to manually resync a single KG-13 would probably be acceptable, but if, for some reason, a power fluctuation should occur and two or more KG-13's lose sync, the resyncing time would be intolerable. It was for this reason that the Auto-Resync unit was designed to take over the manual resynchronization job.

The Auto-Resync Equipment is designed to perform the following functions:

1. Interface with the Inter-Station Communication System equipment at operating rates of between 0 and 50,000 bits per second.
2. Originate a resynchronization when (1) phase lock is lost or (2) in response to a command from the CCC or from the remote Auto Resync Unit.
3. Respond to a request from a remote Auto-Resync, the CCC, or the KG-13.
4. Tally and limit the number of resync operations. This limit is variable and is controlled by security.
5. Verify the validity of resync before releasing the circuit for data operation.
6. Prohibit the transmission of data into or out of the KG-13 equipment.
7. Give an indication whenever a resync operation is in progress.

1 April 1963

63

TM-1146/000/00

The Auto-Resync is considered to be in its Operate mode when it is in a quiescent state (the KG-13 is in a Transmit mode.) On command, the Auto-Resync will be switched into a Resynchronization mode or to an Alarm Check mode. After performing the functions necessary to satisfy the conditions that may exist, it will, if possible, revert back to the Operate mode. Should it fail to obtain a resync condition, an alarm will be given, via the CCC, to the cryptographic operator and to the Bird Buffer.

3.0 TRACKING FUNCTIONAL DESCRIPTION

3.1 GENERAL

Tracking stations are the sensing elements of the SCF. All satellite data enter the data processing system at the STC through the tracking stations. Data transfer between the STC and a tracking station is effected by a CDC 160A Bird Buffer computer at the STC and the two CDC 160A computers at the tracking station, via the 1200-bps line. One of the two CDC 160A computers at the tracking station processes all tracking data; it is called the Tracking and Command (T&C) computer. The other CDC 160A processes telemetry data. There are two modes of operation by which the Bird Buffer interacts with a T&C computer. One mode, called the Satellite-Contact mode, provides real-time support for a satellite. The other mode, the Non-Satellite-Contact mode, effects such non-real-time functions as transmitting-antenna-pointing information, interchanging administrative messages, and forwarding schedule information. Both modes of operation are used in the tracking function.

3.2 PREPASS MESSAGE

A few hours prior to an expected station contact with a particular satellite, an acquisition message is sent from the STC to the T&C computer at the tracking station. This message will have been generated by a 1604 computer at the STC, using all available known and calculated orbital information on the particular vehicle to be tracked. These data are then passed to a Bird Buffer via the 1615 tape unit and are sent to the tracking station during operation in the Non-Satellite-Contact mode. At the tracking station, the acquisition message is stored in the magnetic tape memory of the T&C computer. This message specifies the tracking and telemetry antennas to be used, and the antenna driving information, which consists of azimuth, elevation, and range in local coordinates for successive equal-time intervals over the duration of the pass.

In addition to the prepass acquisition message, an administrative message is sent, which specifies the passes or portions of passes during which the station for each pass is specified, including the number of the pre-wired patchboard that will be used and the manual switch actions that are to be taken.

3.3 ACQUISITION

Five minutes before the scheduled time for the first pass, the SOC operator at the tracking station will switch the slave-data message from the tracking computer to the slave-data bus. These data position the tracking radar antenna in azimuth, elevation, and time to the predicted acquisition point for the vehicle. They also start the raster scan in a search for radar-return signals from the vehicle. If acquisition is not made at the acquisition

3.0 TRACKING FUNCTIONAL DESCRIPTION

3.1 GENERAL

Tracking stations are the sensing elements of the SCF. All satellite data enter the data processing system at the STC through the tracking stations. Data transfer between the STC and a tracking station is effected by a CDC 160A Bird Buffer computer at the STC and the two CDC 160A computers at the tracking station, via the 1200-bps line. One of the two CDC 160A computers at the tracking station processes all tracking data; it is called the Tracking and Command (T&C) computer. The other CDC 160A processes telemetry data. There are two modes of operation by which the Bird Buffer interacts with a T&C computer. One mode, called the Satellite-Contact mode, provides real-time support for a satellite. The other mode, the Non-Satellite-Contact mode, effects such non-real-time functions as transmitting-antenna-pointing information, inter changing administrative messages, and forwarding schedule information. Both modes of operation are used in the tracking function.

3.2 PREPASS MESSAGE

A few hours prior to an expected station contact with a particular satellite, an acquisition message is sent from the STC to the T&C computer at the tracking station. This message will have been generated by a 1604 computer at the STC, using all available known and calculated orbital information on the particular vehicle to be tracked. These data are then passed to a Bird Buffer via the 1615 tape unit and are sent to the tracking station during operation in the Non-Satellite-Contact mode. At the tracking station, the acquisition message is stored in the magnetic tape memory of the T&C computer. This message specifies the tracking and telemetry antennas to be used, and the antenna driving information, which consists of azimuth, elevation, and range in local coordinates for successive equal-time intervals over the duration of the pass.

In addition to the prepass acquisition message, an administrative message is sent, which specifies the passes or portions of passes during which the station for each pass is specified, including the number of the pre-wired patchboard that will be used and the manual switch actions that are to be taken.

3.3 ACQUISITION

Five minutes before the scheduled time for the first pass, the SOC operator at the tracking station will switch the slave-data message from the tracking computer to the slave-data bus. These data position the tracking radar antenna in azimuth, elevation, and time to the predicted acquisition point for the vehicle. They also start the raster scan in a search for radar-return signals from the vehicle. If acquisition is not made at the acquisition

point at the predicted time, the tracking radar follows the predicted orbit, and continues the raster scan about the predicted point, until the vehicle is acquired. During acquisition, the error developed by the raster scan is driven to zero by the servo loop of the tracking radar, which signifies that the antenna is pointed at the vehicle. When this stage is reached, the tracking radar "locks-on" to the vehicle, the predicted acquisition data are removed from the slave-data bus, and the tracking radar begins to supply the antenna driving information for the slave-data bus. For a period of five minutes after acquisition, the tracking data will be compared with the predicted data from the acquisition message by the tracking computer. The results of this comparison are available only at the tracking station and enable the operator to determine whether the actual tracking data and the predicted data are in agreement. If they are not, he must determine whether the fault is local with the tracking radar or whether inaccurate acquisition data were furnished by the STC. In the former case, local correction is made; in the latter case, the STC is notified of the error by means of an administrative communication channel (telephone or teletype).

3.4 TRACK HISTORY

Digitally coded tracking data, taken from the tracking radar and one telemetry tracker, are stored in the tracking computer. There, the data are compressed and sent to the STC in close-to-real time. These data are not printed out at the Bird Buffer but are passed to the 1615 tape units for storage, where they are available for the 1604 orbit determination program. This program fits tracking data from various tracking stations together to find and update the vehicle ephemeris for the preparation of acquisition messages.

4.0 TELEMETRY FUNCTIONAL DESCRIPTION

4.1 GENERAL

It is of vital importance to the satellite research and development programs serviced by the Augmented SCF that adequate and reliable telemetry processing facilities be available. The Augmented SCF is designed to provide these facilities with a degree of flexibility and automation not hitherto obtainable. A unique feature of the Augmentation program is that selected telemetry data received from the satellite vehicle are processed in real time and displayed in the proper engineering units to the Test Controllers, at the same time that the reported events in the vehicle are actually taking place. This is a decided advantage to the technical personnel directing the various programs. The capability exists to change the parameters of a processing algorithm or to change the whole telemetry mode during a pass; however, the latter change occasions the loss of some data during the time the new program is being read into the processing computer. Telemetry operations are under the control of the Test Controllers at the STC and the need for the relaying of information by telephone from the tracking stations to the STC is reserved for emergency equipment failures or unusual situations.

4.2 TELEMETRY PROCESSING OUTPUTS

The STC provides telemetry processing instructions to the TIM 160A computer at the tracking station and provides printout-format instructions with conversion units to the Bird Buffer. The tracking station receives telemetry processing inputs from the prepass module, SPREP, at the STC in the form of instructions on which telemetry points are to be processed, what algorithms are to be used with each telemetry point, and other telemetry processing information. The Bird Buffer receives telemetry data inputs from the tracking station and receives processing instructions from the 1604 pertaining to the printer formats and conversion routines to be used.

Outputs to the tracking station and the remote printers are provided by the STC during the following operational modes:

1. Preflight mode.
2. Prepass mode.
3. Real Time Telemetry Processing mode.

4.21. Preflight Mode. During the Preflight mode, the 1604 (or an off-line computer) generates, from punched-card input, a library tape containing files of mode-specific information. A mode is defined as a specification to the tracking station of the following telemetry information:

1. Selection of the ground station patchboard.
2. Number of TLM link.
3. Processing priority.
4. Format for transmission on the 1200-bps line.
5. Algorithms to be used.
6. Scanner & Digitizer patchboard parameters.

During the Preflight mode, the conversion routines and remote printer formats are specified to the TIM Processing module.

Each flight may have several modes because the telemetry parameters, algorithms, and sampling rates may change from pass to pass. Telemetry information containing the mode-specific information generated during preflight by the 1604 program would be:

1. Preflight TLM messages for each station. Information for all modes of the satellite.
2. Scanner & Digitizer wiring instructions for all modes.
3. Conversion and printer tables for the TIM Processing module at the STC.

Upon request, the Bird Buffer transmits the telemetry processing information, previously stored on the Prepass Tape by SPREP, to the tracking station TIM 160A. The tracking station then performs the necessary functions, as instructed by the preflight telemetry processing information. The TIM 160A has available the necessary information for processing the telemetry data for all modes of the flight. Conversion instructions and printer formats for each mode are available to the Bird Buffer.

4.2.2 Prepass Mode. A card input to the Bird Buffer specifies to the tracking station what mode to use before each pass and generates a mode selection message. Upon confirmation from the TIM 160A at the tracking station that it is prepared to operate in the correct mode, the STC Prepass module reads into core the appropriate mode-specific data for the remote printer format and conversion units.

4.2.3 Real Time Telemetry Processing Mode. During a pass, the TIM 160A transmits to the Bird Buffer three types of FM/FM telemetry: (1) "Fixed Format" Telemetry Parameters, (2) "Event" Telemetry Parameters, and (3) Status and Alarm Messages.

"Fixed Format" Telemetry parameters are printed out once every second and occupy a fixed position in the printer format. "Event" telemetry parameters are printed out as they occur and are identified as to the parameter name or number and the time at which the event occurred. Status and Alarm Messages are printed out as they occur and are printed out in the same area of the printer formats as "Event" type parameters.

During real time, it is possible to change the parameters of algorithms being processed at the tracking station TIM 160A by a card input to the Bird Buffer.

Details of the telemetry processing instructions sent by the Bird Buffer to the tracking station, and the telemetry processing and formatting at the Bird Buffer, are discussed in Reference 4.

4.3 TELEMETRY MODULES AT THE S/C

The Prepass module, SPREP, keeps an updated prepass tape of telemetry processing tables and telemetry mode information. SPREP, upon request, sends the prepass telemetry processing data to the tracking station.

If a change in telemetry selection is requested during bird contact, SPREP reads in the appropriate telemetry processing tables from the first files of the prepass tape. The telemetry processing tables needed for bird contact are located in the first files to minimize tape search. SPREP obtains its telemetry information for its prepass tape from either the 1604 computer or through manual inputs. The telemetry processing tables and telemetry mode information messages, which are not pass specific, are made up by a 1604 program preflight and stored on the prepass tape by SPREP. New modes should be carefully validated before they are used, however.

The Telemetry Processing module, STEPP, generates a table of instructions describing the printer format and conversions to be used by the Bird Buffer. STEPP accepts telemetry data from the tracking station, performs the necessary conversions, and prepares specific telemetry parameters for printout on the 166 printers.

4.4 DATA FLOW AT THE TRACKING STATION

A block diagram of the FM/FM Ground Station used with Augmented SCF tracking stations is shown in Figure 10. Outputs from other telemetry sources (GP-1's and FCM) are shown as inputs to the Switching Matrix. Telemetry signals transmitted from the satellite are received by the TIM antenna, pass through the pre-amp and multicoupler, and are sent to the FM receivers. The multicoupler provides an r-f composite signal of all TIM links to usually four FM receivers.

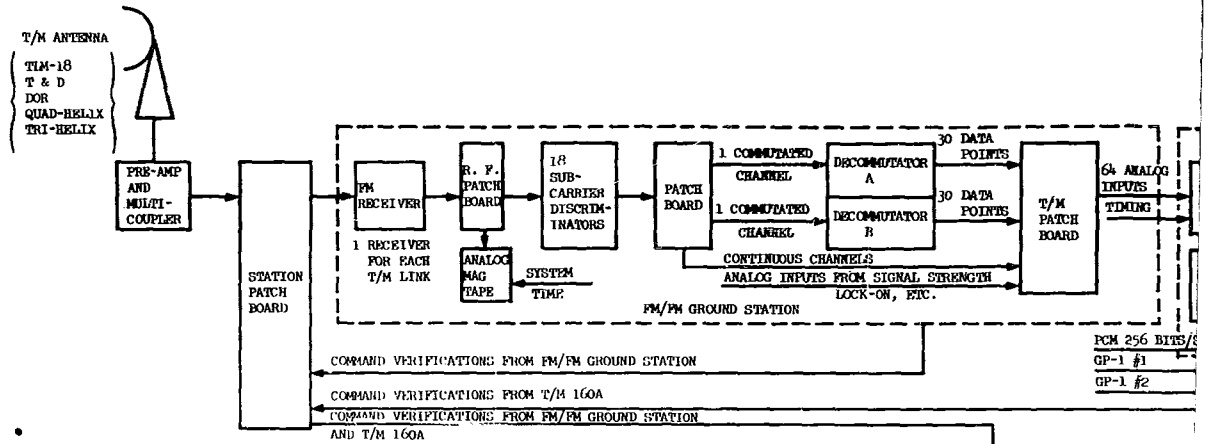

ABBREVIATIONS:

- SOC STATION OPERATOR'S CONSOLE
- CLE COMMAND LOGIC EQUIPMENT
- IOB INPUT-OUTPUT BUFFER
- PCM PULSE CODE MODULATION TYPE TELEMETRY (IN DIGITAL FORMAT AT A BIT RATE OF 256 BITS/SEC)
- GP-1#() DIGITAL FORMAT PROVIDED BY OUTPUT OF THE GENERAL PURPOSE GROUND STATION WHICH PROCESSES FAN/FM TYPE TELEMETRY. DIGITAL OUTPUTS MAY BE FROM EITHER TWO GP-1'S AS INDICATED BY #()
- CCC COMPUTER COMMUNICATION CONTROL
- MODRM MODULATOR AND DEMODULATOR
- KG-13 CRYPTOGRAPHIC UNIT
- CDC 161 TYPEWRITER
- CDC 163-() MAGNETIC TAPE FRAMES (THE DASH NUMBER INDICATES THE NUMBER OF HANDLERS)
- CDC 166-2 PRINTERS (2)
- CDC 169 EXTERNAL MEMORY (8K)
- CDC 160A COMPUTER (8K)
- CDC 1604 COMPUTER (32K)
- CDC 1615 MAGNETIC TAPE FRAME
- CDSCCU COMMUNICATION DATA SELECT & CROSS CONNECT UNIT
- CSCCU COMPUTER SELECT & CROSS CONNECT UNIT

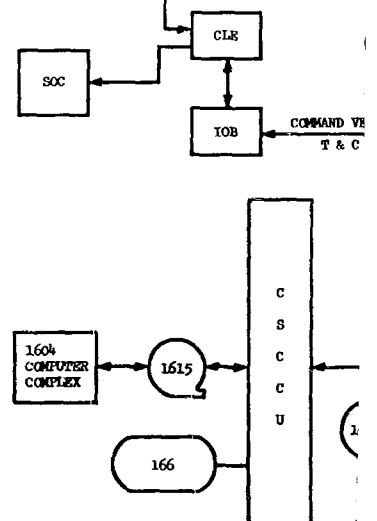

Figure 10. Augmented SCF

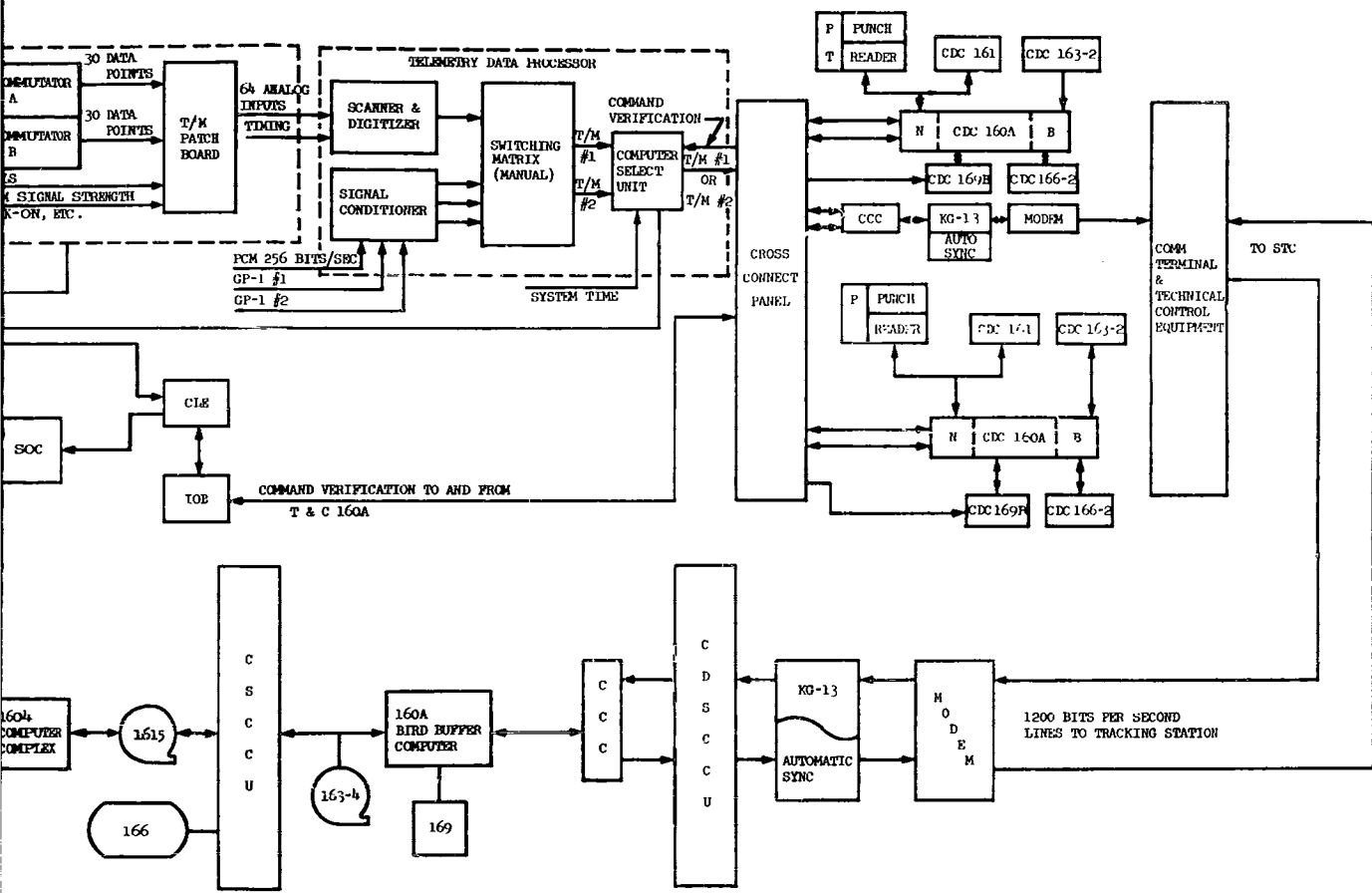

Figure 10. Augmented SCF Telemetry Data Flow

The outputs of the FM receivers are then routed simultaneously to the 7-track analog tape recorders and the 18 subcarrier discriminators (SCD's). Four tracks of the analog tape recorder are used for recording the outputs of the FM receivers (one to each track), while the other three tracks are used for system time, reference signals, receiver signal strengths, and voice. The outputs of the SCD's are fed to a patchboard, where two commutated channels selected from the SCD's are routed to two decommutators. Each decommutator has the capability of decommutating 30 data points from each commutated channel. A total of 64 data points are fed into the Scanner & Digitizer through the TLM patchboard. The 64 data points consist of outputs from the two decommutators, the continuous channels, the receiver signal strength lock-on indicators, and other analog function. The 64 analog inputs can be sampled at a maximum rate of 25 kc and a minimum rate of 5 cps. The digitized outputs of the Scanner & Digitizer (8-bit words) can be fed into the Switching Matrix together with three digitized inputs from the two GP-1's and PCM equipment. The Switching Matrix manual patchboard outputs two of the four inputs to the Computer Select Unit (CSU). The TLM 160A, which controls the CSU, selects one of the two telemetry inputs to the CSU for processing. The telemetry data are processed, compressed, and formatted by the tracking station general-purpose telemetry program, TIMOP. Information concerning the data points to be processed, the specific algorithms associated with each data point, the sampling rates to be used, and other telemetry processing is sent, during the preflight, prepass, and real-time telemetry-processing modes, from the STC Bird Buffer by the Prepass module, SPREP.

The outputs of the TLM 160A computer (and the T&C 16CA) are controlled by the Computer Communication Converter (CCC). Outputs of the CCC are passed through the KG-13, MODEM, and then to the STC over the 1200-bits/sec communication lines.

4.5 DATA FLOW AT THE STC

At the STC, data from the tracking station pass through the MODEM and the KG-13, and are received by the CCC and transferred to the Bird Buffer. At the Bird Buffer, the Telemetry Processing module, STEPP, converts the telemetry data to the desired engineering units and outputs preselected data points on the various remote printers.

4.6 TELEMETRY OPERATIONAL PROGRAM (TIMOP)

TIMOP is a general-purpose operational program for processing, formatting, and controlling the transmission of telemetry data at the tracking stations. TIMOP is, in general, non-satellite-specific and can process each type of data processed by the Telemetry Data Processor (TDP).

TIMOP operates in prepass, pass, and postpass functions. The prepass function is used to receive and process prepass instructions from the STC during the Bird Buffer's preflight and prepass modes. The instructions contain information concerning telemetry processing, as specified by the STC Prepass module, SPREP. The tracking station prepass program stores and prints out, upon direction, prepass messages for each vehicle.

This printout could include a schedule of all vehicles and ETA's contained in the prepass message. During the pass function, which corresponds to the Bird Buffer's real-time telemetry mode, TIMOP accepts digital telemetry data from any one of four sources (TDP, two GP-1's, or PCM) and processes these data in accordance with instructions from the STC. TIMOP, during the pass function, supplies a system-time code word (STCW) and the compressed telemetry data to the STC. The following functions are accomplished in the telemetry processing by TIMOP:

1. Reasonableness checks of telemetry data.
2. Smoothing calibration points and normalization of data, if required.
3. Compression of acceptable data and reporting of step function levels, periodic time tagged data-point values, time-tagged data-point minimum/maximum values, time of event, and other functions as required.

The STC can request TIMOP to process different telemetry points and to use different algorithms during a pass. TIMOP can detect a command verification in the digital telemetry input to the TIM 160A. TIMOP transmits this information to the STC and prints it on a 166 printer at the tracking station. Command verification information may also be transmitted to the T&C 160A, if required.

The data for the postpass program are obtained from either digital or analog tapes recorded during the pass function and are transmitted to the STC during the Bird Buffer's Real-Time mode. The STCW on the tape corresponds to the system time when the data were recorded. The tracking station configuration and telemetry processing information during postpass is the same as that specified during the pass function. If desired, telemetry data can be displayed on a 166 printer without transmission to the STC.

5.0 COMMANDING FUNCTIONAL DESCRIPTION

5.1 GENERAL

The ability to control the functions of a satellite vehicle and its payload is just as important as the ability to acquire and track it. Control of a satellite depends upon the ability to establish two-way communication with it while it is in orbit. Two-way communication is necessary to allow the Test Controller to send his commands to the satellite and to verify that they have been received and executed. The requirements for commanding a satellite vary with the type of satellite and its mission. The means of accomplishing the command function vary accordingly.

In general, commands are transmitted to satellite systems to perform the following types of functions:

1. Set or reset a Fairchild timer and shorten or lengthen timer periods. (The Fairchild timer turns equipment in the satellite on or off at predetermined times.)
2. Send Stored Program Commands (SPC's) to turn equipment on or off at the proper time.
3. Turn beacons, payload, or telemetry systems on or off with Real Time Commands (RTC's).
4. Adjust or calibrate internal systems; initiate special events such as engine ignition, separation, or recovery.

Different techniques are used to modulate the various transmitters used for commanding in order to effect the transmission of commands to the satellites. These are explained in detail in Reference 3. There are two main types of command systems that are of interest: analog systems and digital systems. The analog systems utilize a three-pulse-group transmission, with command information carried by time modulation of the center pulse. (See Figure 11.) The digital systems use various forms of modulation, such as tone or pulse spacing, to send a "one" or "zero" each time a pulse-code group is transmitted. A succession of these binary bits form digital-command words, which the logic in the satellite command package translates into relay closures at specific times.

Two different equipments are used for communicating commands from tracking stations to satellites. One is S-band (2.7-2.9 Kmc) command equipment used with the Verlort and Prelort radar antenna systems. The other is the UHF (375-400 mc) equipment used with the TIM-18 telemetry antenna system and the Telemetry and Data (T&D) antenna system.

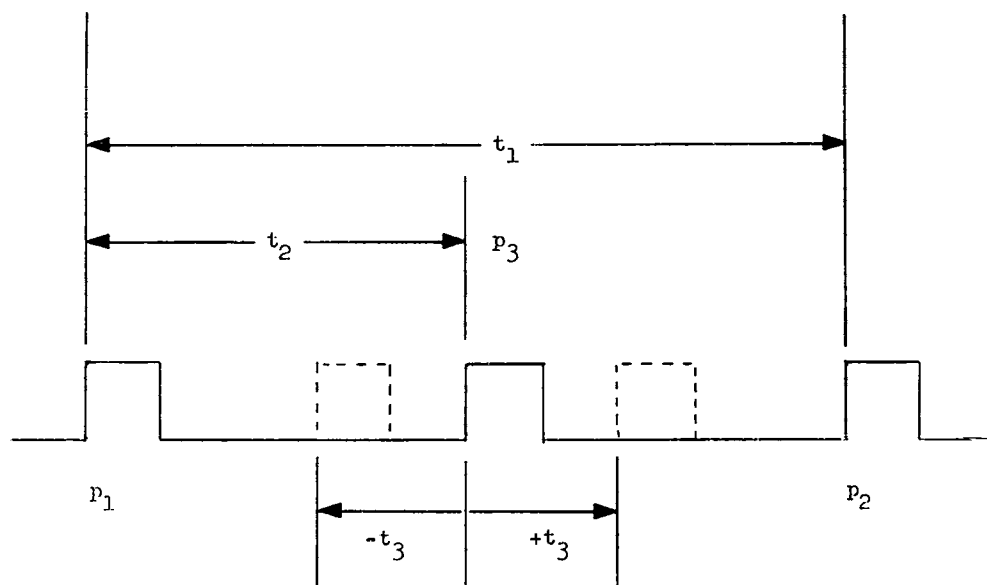

t_1 can be set to one of six different intervals and is used as the code address for a particular vehicle, which will not respond to pulse trains having a different t_1 interval.

Two linearly mixed audio tones are used to time-vary the position of pulse p_3 , causing it to vary about its center position by a maximum interval of $\pm t_3$.

p_1 , p_2 , and p_3 represent the pulse train that modulates the transmitter. It is repeated at the pulse repetition rate of the transmitter being used for commanding.

Figure 11. Analog Pulse Modulation Scheme

There are two different modes of operation for both Analog and Digital commanding: the Manual mode and the Computer Automatic mode. In the Manual mode, commands are initiated by operations personnel at the tracking station by means of switch actions at the System Operators Console (SOC). In the Computer Automatic mode, commands are automatically provided and executed by the Tracking and Command (T&C) computer.

5.2 ANALOG COMMANDING--MANUAL MODE

Four submode options are available in the Manual mode of the Analog Commanding System: Single, Long, Repetitive, and Remote.

In the Single submode, the operator at the SOC sets a rotary switch to a number representing one out of a total of fifteen possible commands. He then closes the "Transmit" switch. The Command Logic Equipment (CLE) translates this into the closure of two relays out of bank of six. Each relay determines a different audio tone for time-modulating the output pulses of the transmitter being used for commanding (Figure 11). The command package in the satellite has logic circuitry which translates the two tones into one of fifteen different commands. Verification that the proper command was sent from the transmitter is made in the form of an echo check. This echo check is derived by sampling the transmitted radio frequency signal, demodulating it to recover the two tone modulating signals, and converting them to a pair of relay closures, which are compared with the original relay closures by the CLE. If the original command stored in the CLE and the command returned from the radio frequency monitor on the command transmitter are in agreement, the CLE sends an "Echo Check" indicator to the SOC and the T&C computer. If they do not check, a "Command Error" indicator will be sent to the SOC and T&C computer. Further commanding through the CLE will be prevented until the "Error Override" switch on the SOC has been actuated. Verification that the satellite has received the correct command is made in the following way: relays in the satellite that are actuated by the command signals from the command transmitter have contacts which are used to modulate channels in the space-to-ground telemetry link; these channels are received by the ground equipment and demodulated by the FM/FM ground station, which sends two relay closures to the CLE for verification; the CLE compares the relay closures with the original command-relay closures and sends an indicator to the SOC and the T&C computer as to whether the command was received correctly or was in error; and display lamps on the SOC, which are similar to the "Echo Check" displays, indicate the status of the command.

Additional SOC displays derived from the CLE and displayed in decimal digit format, are: (1) Command Number Selected, (2) Command Transmission Count (number of times that the command was transmitted), and (3) Vehicle Verification Count (number of times that the command was verified).

The Long submode of the manual mode permits the operator of the SOC to continue to transmit a command as long as he keeps the Transmit push button depressed. Otherwise, the functions and displays are similar to the Single submode.

Operation in the Repetitive Transmit submode allows the SOC operator to select, by switch action, the number of repetitions with verification of a command which the CLE is to automatically make. The CLE will repeat the whole procedure described for the Single submode at the rate of one command repetition for each two-second interval of time. When the command repetition number is reached, the command transmission will stop. The SOC operator may stop the repetitive action by pressing the "Stop Repetitive" push button. If a "Command Error" occurs on any of the repetitions, further transmission will be inhibited. Transmission of the remaining command repetitions will resume when the "Error Override" push button is actuated. All other functions and displays are the same as for the Single submode.

The Remote submode is identical to the Single and Long submodes, except that command control will be executed from a remote console.

One satellite system, which uses a special console and special logic equipment in the satellite, is able to handle more than the maximum number of 15 analog commands. This is accomplished by sending a sequence of three tone-pair combinations, which the satellite equipment translates into a single command.

5.3 ANALOG COMMANDING--COMPUTER AUTOMATIC MODE

In the Computer Automatic mode, blocks of commands are stored in the core memory of the T&C computer. These blocks are made up of RTC's arranged in the proper order for transmission to the satellite. (See Section 5.6 for the description of how these commands are made up at the STC and transmitted to the tracking station as part of the prepass acquisition message.)

The SOC operator, by pressing the "Computer Auto Command Mode" push button, places the system in the Computer Automatic mode. A switch action at the SOC designates the number of the block of commands to be sent to the satellite. Actuation of the "Transmit" push button on the SOC initiates the sending of the entire block of commands under the control of the T&C computer. The identification of each command sent, plus indications of echo checks completed and verifications received from the satellite, will be displayed at the SOC in the same manner as for the Manual mode. Also, the T&C computer will make the usual records of command status. Automatic transmission of commands will be inhibited if either an echo check or vehicle verification check fails, and an alarm display will be activated on the SOC. Error override controls are available on the SOC to permit the operator to restart the automatic command sequence. The computer command program may be stopped by pressing the "Computer Auto Stop" push button at the SOC. It can be restarted by pressing the "Transmit" push button. Displays on the SOC indicate: (1) when the appropriate computer command program has been loaded in the computer and 1

ready for transmission; (2) when the computer command program is in progress, transmitting commands to the satellite; and (3) when the program has been completed.

5.4 DIGITAL COMMANDING -- MANUAL MODE

Digital command requires more extensive use of the T&C computer than does Analog commanding. The T&C computer maintains, in its memory files, a repertoire of RTC's which will be used in the Digital Manual mode of commanding. The repertoire of commands is sent to the T&C computer, initially, as part of the command portion of the initial prepass message. Subsequently, the repertoire is maintained in a current status through the addition or deletion of commands by later prepass messages. The SOC operator can call up a command from the repertoire by setting the "Number Select" control on the SOC to the number of the command desired and pressing the "Transmit" push button. The T&C computer, in response to the switch action, provides the corresponding digital-command word to the CLE, via the Input-Output Buffer (IOB), serially bit-by-bit, on a computer-interrupt basis. The CLE will output the command, serially bit-by-bit, to the modulating equipment of the command transmitter. The transmitted signals are subject to an echo check, made by the computer, which compares the echo returns from the command transmitter, bit-by-bit, with the original command word stored in computer memory. Echo check errors will be displayed on the SOC and recorded by the T&C computer. In the satellite command package, the received command word will be checked for parity and checksum. If the word passes this combined check, the command is accepted and the "accept" channel of the telemetry package is used to send a "word accept" verification to the ground. If the word check fails, a "word reject" notification is sent to the ground via the "reject" channel of the telemetry package. This acceptance or rejection of the command by the satellite will be displayed on the SOC and will be available to the computer for recording. Additional controls and displays that are available to the operator of the SOC are:

1. Reject Level Select Control--sets the number of times a command will be automatically repeated when not verified.
2. Reject Level Display--indicates the level selected by the Reject Level Select control.
3. Reject Count Display--indicates the number of times a command has been rejected.
4. Command Reject Display--indicates the number of the command that was last rejected by the vehicle.
5. Command Verify Display--indicates the number of the command that was last accepted by the vehicle.
6. Spoof Display--indicates that a false accept or reject signal

was received from the satellite while a command word was in the process of transmission.

7. Repetitive Number Select Control-- sets the number of times a command will be transmitted and verified.
8. Reject Count Clear Control--sets the Reject Level Display to zero and allows the computer to resume the command transmissions that were inhibited when the reject level was reached.

Four submode options are available in the Manual mode of the digital commanding system: Single, Repetitive, Manual Control and Display Unit (MCDU), and Remote.

In the Single submode of operation, a command will be transmitted and verified only once each time the "Transmit" switch is actuated from the SOC. If a transmission is not verified, the T&C computer will retransmit the command until it is accepted by the satellite, or until the reject level set by the Reject Level Select Control is reached. Operation of the Reject Count Clear Control on the SOC will allow the computer to resume command transmission after the reject level has been reached.

In the Repetitive submode of operation, the SOC operator sets the Repetitive Number Select Control Switch to the number of times he wants a command to be repeated and verified by the vehicle. The computer will continue re-transmitting the command until this number is reached. Other controls and displays are the same as for the Single submode.

The Remote submode enables a remote console to assume command control. Only the Single submode type of operation previously described is allowed from the remote console. These controls and displays, identical to those on the SOC, will be provided to the remote console: Command Number Select Switches, Transmit Switch, Error Override Switch, Reject Override Switch, Command Verification Display, Command Echo Check Error Display, and Command Reject Display. The status of the remote console will be indicated on the SOC by three displays: the Remote Command Ready, the Remote Command in Progress, and the Remote Command Complete.

The MCDU submode makes provision for transferring command control to the MCDU console (G.E. 702). A digital command, selected from one of six command switches on the MCDU console, will be transferred to an encryptor keyboard, a security classified device in the CLE. The keyboard will translate the switch closure to a 7-bit command, which will be provided in parallel to the computer via the IOB. The computer will store the Command in core memory and then proceed to output the command to the CLE, serially bit-by-bit, at the synch PRF rate of the command transmitter. Echo check on the transmitted command words will be handled in the usual manner. The

command selection made by the MCDU operator will be made available to the T&C computer for recording. Two displays on the SOC will notify the SOC operator of the status of the MCDU console: the MCDU Ready and MCDU Complete.

5.5 DIGITAL COMMANDING--COMPUTER AUTOMATIC MODE

In the Computer Automatic mode, command control is transferred from the SOC to the T&C computer for the transmission of a block of commands. The block of commands may consist of RTC's and SPC's (see Section 5.6). Once the SOC operator has set the "Command Block Number" switch to the proper command block number, and pushed the "Transmit" push button, the T&C computer proceeds to send the entire block of commands to the CLE in proper sequence for transmission to the satellite. Echo check and verification are the same as for the Manual mode. Automatic transmission will cease if verification is not obtained prior to reaching the present reject level. The SOC has override controls available for both echo check errors and vehicle word rejects.

Manual override controls permit the computer to retransmit or proceed to the next command word when the computer command sequence has stopped because of an echo check error and verification, or when a word reject is received, or if the word reject level has been attained.

5.6 STORED PROGRAM COMMANDS

A satellite-specific command program for each satellite system is available in the computer library to enable a 1604 computer to prepare command messages for transmittal to the tracking stations. The programs format real time commands (RTC's) and stored program commands (SPC's) in response to command requests initiated by operations personnel via the 088 card reader, the 350 paper tape reader, or magnetic tape input. They determine auxiliary real-time commands (ATC) to control the Parchild timer operation, as required by some satellite systems. They also establish the relationship between vehicle and system time, and determine delay line assignments for storage of SPC's in the satellite memory.

Some time prior to the predicted time of a particular pass, the Test Controller, in preparation for the impending satellite operation, makes up his command requirements on data cards, which are read into a 1604 computer via the IBM 088 card reader. The 1604 then makes the necessary computations to compile a command list that satisfies the Test Controller's requirements. A printout of the command list, with execution times and other pertinent data, is furnished to the Test Controller by means of the 1612 printer. The Test Controller checks this command list and inserts such corrections as are necessary via the 088 card reader. The 1604 then makes up a command message in the proper format for transmission to the tracking station. This message is stored in a 1615 tape unit with the rest of the prepass acquisition message, which consists of commands, schedules, telemetry mode processing parameters, and antenna pointing data. Figure 12 is a simplified

schematic of the inputs to and outputs from the 1604 during this operation.

When the Computer Switching and Cross Connect Unit (CSCCU), under control of the Switch Control computer, connects the 1604 computer to a 160A Bird Buffer through the 1615 tape unit, the acquisition message is transferred to the Bird Buffer in the sequence of events described below and illustrated in Figure 13.

The Test Controller inserts a function card into the CDC-167 Card Reader associated with the Bird Buffer. The Bird Buffer will test the 1604 communication flag to determine if the 1604 can be interrupted. (The 1604 cannot be interrupted by the Bird Buffer while it is engaged in another operation.) If the communication flag indicates the 1604 cannot be interrupted, the Bird Buffer will print a message telling the Bird Buffer operator that it is going into a loop until the 1604 becomes available, and what jump action should be taken to abort the attempt. It will then enter a tight loop, continually testing the communication flag and the jump switch. If the flag is cleared while the Bird Buffer is in the loop, it will notify the operator that the transfer is starting and will interrupt the 1604. If the jump switch action is taken before the flag is cleared, the attempt to communicate will be aborted, and can be initiated only by another card input to the Bird Buffer. The flag will be cleared for a three second interval at least once between successive 1604 functions to allow interrupt by the Bird Buffer. If communication with the 1604 in real time is anticipated, the 1604 can be put into an idle loop by means of a function card inserted by the 1604 operator, and it will then "wait" for an interrupt from the Bird Buffer. When the 1604 is free it will act on the interrupt and initiate the transfer. When ready, the 1604 reads the first message (64 words) of the prepass message into core and starts a core-to-core transfer from the 1604 to the Bird Buffer by means of 1615 tape unit operating in the satellite mode. Verification of the message transfer will be made for each message before proceeding with the next message. Although the complete prepass message is checked for parity and checksum errors, the command portion of the message will, in addition, be subjected to a bit-by-bit comparison between the message transmitted to the Bird Buffer from the 1604 and the same message returned to the 1604 from the Bird Buffer for verification. The comparison is done by a 1604 program which, when it detects an error, will retransmit the message until bit-by-bit correspondence is achieved. The 1604 then sends a verification message to the Bird Buffer, which requests the next block from the 1604. This procedure is continued until the complete verified command message is transferred to the Bird Buffer core. The Bird Buffer now transfers the prepass message to tape storage (163). It is read back into core from tape storage and verified in the same manner as was the original transfer from the 1604 to the Bird Buffer. After verification, the prepass message is held in the magnetic tape unit until time to transfer it to the tracking station. At this point, the 1604 is through with this particular message and all further handling and verification will be accomplished by the Bird Buffer. The capability also exists to read prepass information directly into the Bird Buffer command files from

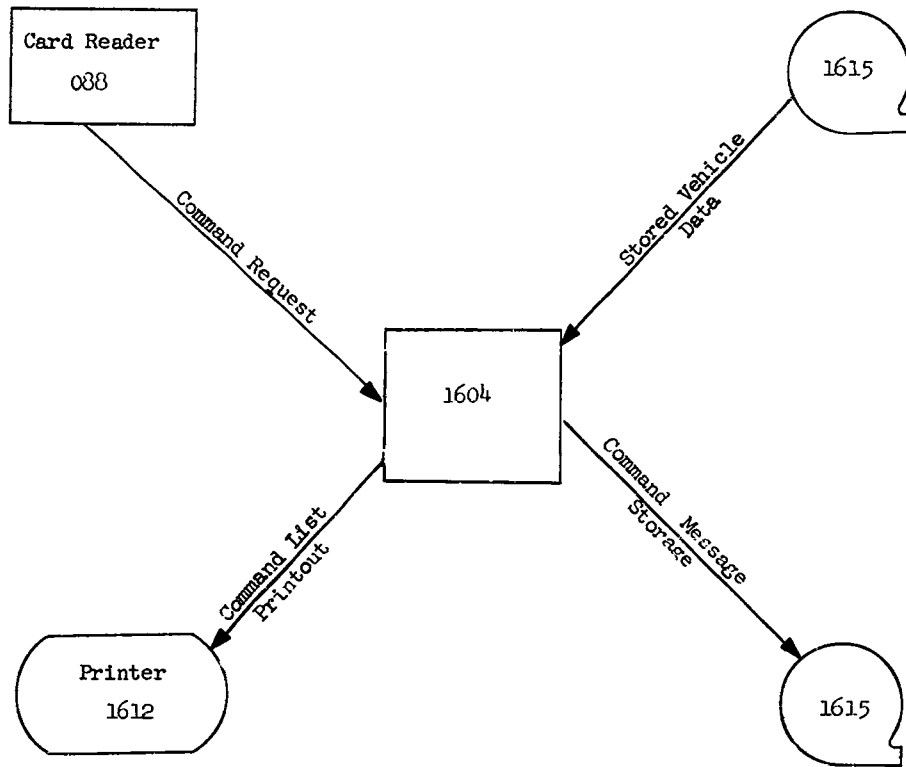
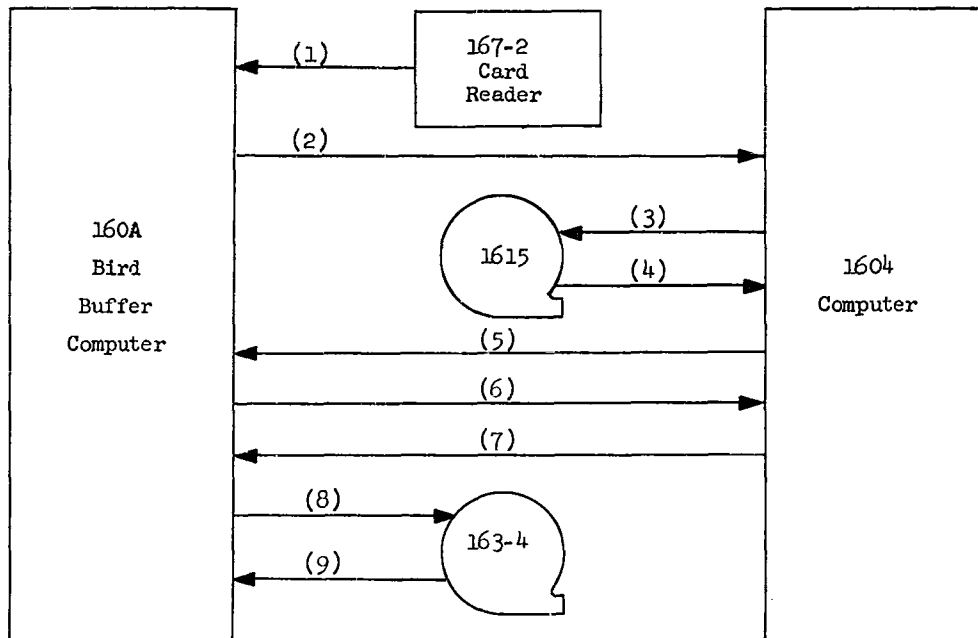

Figure 12. Command Message Preparation--Inputs and Outputs



1. Initiate request for prepass acquisition message.
2. Interrupt and request for data.
- 3-4 Read command message into core from magnetic tape.
5. Transmit command message from 1604 to 160A.
6. Transmit command message from 160A to 1604 for bit-by-bit verification.
7. "Command message correct" verification.
- 8-9. Store and verify message in 163 tape unit for future transmission to tracking station.

Figure 13. Transfer of Command Message from the 1604 to the Bird Buffer

cards. Certain "vehicle specific" commands, which need to be available at the tracking station for every pass over the station, will be sent only once to the station, and will not be included in the prepass message for each pass.

A short time before a tracking station is scheduled to contact a satellite, the switch control computer at the STC will connect the Bird Buffer to the computer at the tracking station by means of the Communication Data Select and Cross Connect Unit (CDSCCU). The operation of transmitting the prepass acquisition message is initiated manually by operations personnel at the tracking station by causing the two 160A computers at the tracking station to send a "Real Time Near" message to the Bird Buffer. This is done about ten minutes before the expected acquisition time of a satellite pass. Transmission of the prepass message may also be initiated at the Bird Buffer by means of a function card. Additional data may be manually appended to the command message at this time.

Transmission and verification of the command part of the prepass message from the Bird Buffer to the T&C computer at the tracking station is handled in a manner similar to its transmission and verification from the 1604 to the Bird Buffer. The Bird Buffer will read the message into core from tape storage and initiate a core-to-core transfer to the T&C computer. The T&C computer will check parity and checksum for errors and, if none are found, will retransmit the command message, a block at a time, to the Bird Buffer. A Bird Buffer program will make a bit-by-bit comparison for each message before sending a verification for that message. When the complete prepass message has been verified in core memory at the tracking station, it will then be transferred to magnetic tape, using the same verification scheme employed by the Bird Buffer. When the complete message has been verified and successfully stored in the 163 tape units, a text message to that effect will be sent to the Bird Buffer. The Bird Buffer will do the necessary bookkeeping on its files to keep track of the prepass data that has been sent to a tracking station so that only new information will be sent in the prepass message; old data referred to previous revolutions will be deleted from the prepass data stored in the 163 tape units. Figure 14 shows the data flow involved in this transfer.

Part of the prepass message is a text message which has the schedule for the nominal times to transmit the various commands in the repertoire of RTC's. This text message also contains command-specific instructions to the SOC operator.

5.7 REAL-TIME COMMANDS

Real-time commands may be initiated in a number of different ways. They may be generated in a 1604 computer in response to card inputs from the Test Controller. Command messages may be input directly to the Bird Buffer by card, in which case they must be made up in the proper command message format.

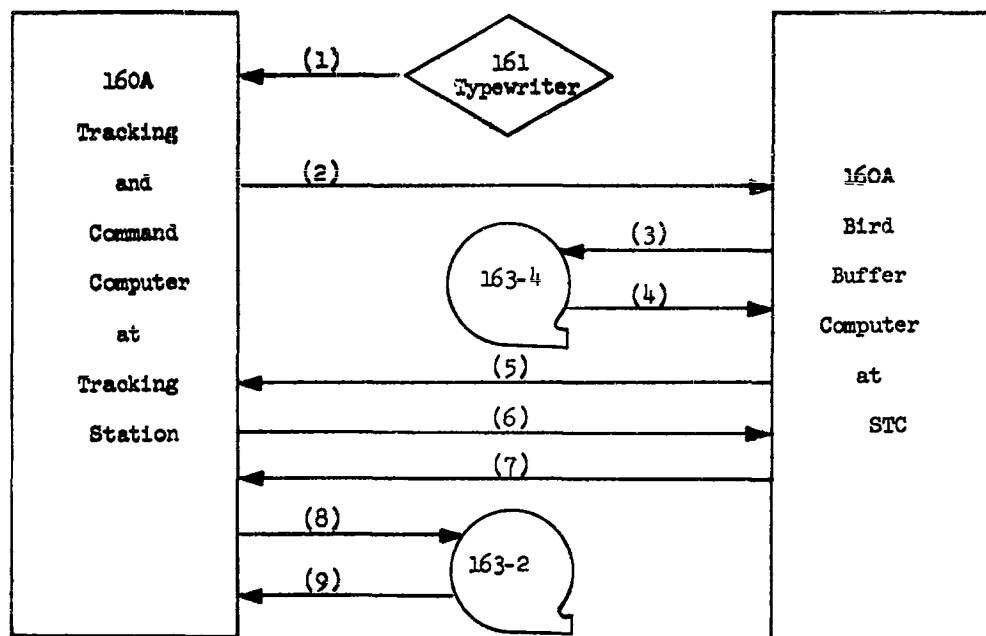

1. Initiate request for prepass acquisition message.
2. Request for data.
- 3-4. Read command message into core from magnetic tape.
5. Transmit command message from BB to T&C computer.
6. Transmit command message from T&C computer to BB for bit-by-bit verification.
7. "Command Message Correct" verification.
- 8-9. Store and verify message in 163 tape unit for future transmission to satellite.

Figure 14. Transfer of Command Message from Bird Buffer to T&C Computer at Tracking Station

Commands may be initiated at the tracking station SOC, where capability exists to call up commands from the command repertoire stored in the T&C computer. Some programs have special commanding requirements and for this purpose, special "back room" consoles are provided from which commanding is initiated and controlled.

Commands generated by the 1604 for real-time transmission to the tracking station are handled in much the same way that the block commands previously described are handled. They are made up by the 1604 from data tables, put into proper message format, and transmitted to the Bird Buffer with the same verification procedure. However, as RTC's can be sent only when the Bird Buffer is operating in the station contact mode, there is no need to store the command messages on magnetic tape prior to transmittal. Instead, the messages are transmitted to the tracking station immediately after verification is received from the 1604. The command message is recorded on the 163 tape unit along with all other data received or generated by the Bird Buffer system while operating in a real-time mode. The same core-to-core transfer and bit-by-bit verification of command messages between the Bird Buffer and the T&C computer is used for RTC's as is used for SPC's. Again, at the tracking station, as at the Bird Buffer, the command message is not read into tape storage but is stored in core, where it is available for immediate use.

5.8 COMMAND HISTORY

The command function, having such a vital part in the accomplishment of a satellite's mission, requires special arrangements to insure that the commands received by the satellite are accurate, and that their operational status will be available for postpass analysis. Accuracy is maintained by the elaborate verification procedures previously discussed, while the methods used for handling command data insure that a complete record is preserved of all commands sent. During real-time station contact between the tracking station and the Bird Buffer, Command Operational Status Report messages will be made up by the T&C computer and sent to the Bird Buffer. These messages will be sent in near real time and will report the status of all commands sent to the satellite. These messages will contain the following detailed information on each command:*

1. Command or command block number.
2. Time of report.
3. Time command was transmitted.
4. Report number--reports will carry sequential numbers.
5. Status of command (where applicable):

* From Reference 4, p. 60

- a. Accepted or verified.
- b. Wrong verification on analog command.
- c. Digital command rejected. If the reject occurs on a command block, the number of step within the command block will also be given.
- d. No accept, reject or verification was received.
- e. Error was overridden by SOC action and command retransmitted.
- f. Spoof--Spurious verify or reject received during transmission
- g. A change in address, line, matrix, etc., was performed in transmitting this command. The new condition will also be included.
- h. An echo-check error was detected during transmission. If the command was accepted by the satellite despite the echo-check error, the image of the command will be sent with a "1" bit in the position corresponding to the bit in error.
- i. The command sequence was advanced. This pertains to blocks of commands and the number of advances will be included.
- j. The command in question is needed at the tracking station but is not available and must be sent from the STC. This report may be the result of tape parity errors encountered at the site.

In addition to the command data from the tracking station, all real-time commands formatted and sent from the 1604 computer or originated by card input to the Bird Buffer will become a part of the command record. These reports will be printed out in near real time for the information of the test controllers. The reports will also be stored in the Bird Buffer magnetic tape memory. In the post-pass period, the Bird Buffer will, on request, search the tapes for these command records and will print out a collected time-sequenced history of the commanding operations for that particular pass.

6.2 INPUT PROCESSING MODULE

This module provides the data required for the operation of the other SCHOPS modules and maintains a history of the events which occurred during the last scheduled interval. The module utilizes the following five types of inputs:

1. Orbital and tracking station parameters.
2. Radio-frequency-interference (RFI) data on satellites controlled by other agencies.
3. Status information and descriptive data on the resources of the satellite systems, the tracking stations, and the STC.
4. Logical parameters essential to operation of the scheduling modules, and subject to variation by the Multi-Ops Controller.
5. Overrides by the Multi-Ops Controller which take precedence over decisions of the scheduling program.

With these inputs, the module generates rise and fade times, with azimuth and elevation, for each satellite and tracking station

6.3 CONFLICT PREDICTION MODULE

Using the data made available by the Input Processing module, this module predicts the occurrence of four types of conflicts:

1. Satellite conflicts--this type of conflict is the result of more than one satellite requiring the services of a tracking station at the same time.
2. Coverage conflict--this conflict is the result of one satellite being in view of more than one tracking station. The conflict arises because the Bird Buffer assigned to the satellite can only work with one station at a time.
3. Printer conflict--when more than one satellite of the same flight program is being serviced by different tracking stations, there is a conflict at the printer in the program room if more than one Bird Buffer attempts to pass information to the printer.
4. RFI conflict--this conflict occurs when one or more SCF or non-SCF satellites are in close proximity to, and are transmitting in the same frequency range as, a SCF satellite being serviced by a tracking station. This could result in radio-frequency interference with the satellite-to-ground communications.

The results of these conflict predictions are made available to the Conflict Resolution and Output Processing modules for preparation of printouts.

6.4 CONFLICT RESOLUTION MODULE

This module resolves the satellite and coverage conflict situations described above, and generates a listing of the resolved vehicle/station contacts. Conflict resolution is done in three phases (I, II, and III) and is responsive to input priorities and to the value judgements of operations personnel.

Phase I selection is based on mandatory pass coverage, as designated by the Multi-ops Controller.

Phase II selection is based on computations to derive priorities for each vehicle. These priorities include: (1) gain to the system resulting from required frequency of contacts; (2) gain due to contact time; (3) gain for specific contacts, independent of time; and (4) initial priority at the start of a resolution period. The algorithm for resolving conflicts in phase II optimizes the priority function over the space of possible pass combinations for each resolution period. The results produce a sharing of time between satellites at single stations and between stations for a single satellite, depending on the type of conflict being resolved.

Phase III selection assigns the inactive vehicles to the remaining possible service time, using vehicle-specific, constant priorities to resolve conflicts.

6.5 RESOURCE ALLOCATION MODULE

This module has three submodules: (1) Transmission, (2) 1604 Scheduling, and (3) Switch Scheduling. The Transmission submodule allocates time for communications between the Bird Buffers and the tracking stations for the Non-Real-Time mode. It optimizes the assignment of non-pass time, using message requests, priorities, and other message related parameters as inputs. The 1604 Scheduling submodule assigns tasks to the four 1604's. These tasks consist of: (1) flight support operations (2) general support operations such as scheduling and (3) non-support operations such as program validation and acceptance. The inputs are requests, priorities, pass-time, and other parameter values.

There are two modes of operation in the 1604 Scheduling submodule. One is the Look-Ahead mode, which covers a long period of time. The schedule which is generated in this mode is used as a planning tool. The other mode is the Short-Term mode; the schedule generated is the final working allocation of 1604 time.

The Switch Scheduling submodule allocates the SCF equipment to be used to perform multi-vehicle support by generating a switching schedule for the CDCCU and CDSCCU. An interim switching schedule is made up by merging a

table produced from the Conflict Resolution lists with the availability table from the Transmission submodule and the Flight Support Computer Time Requirement table. The final switching schedule is generated by combining the interim schedule with the Vehicle Equipment Requirements table. A magnetic tape of the final schedule is prepared by the Output Processing module and hand carried to the Switch Control computer. The Switch Control computer causes the CSCCU and CDSCCU to connect and disconnect the various station and equipment in accordance with the prepared schedule.

6.6 LAUNCH PLANNING MODULE

This module is used to determine the optimum time to launch a new satellite. The module predicts the number of conflicts that would be generated if the vehicle was launched during each 10-minute interval of the launch window. It lists the passes in which the conflicts occur, the nature of the conflicts and the vehicles involved. Two types of conflicts are considered, Satellite and Coverage (see Conflict module). The Output Processing module prepares a printout of this list for the use of control personnel in planning the best launch time.

6.7 OUTPUT PROCESSING MODULE

This module prepares outputs from the data generated by the other SCHOPS modules. These outputs are printouts or magnetic tapes. The list of outputs prepared is as follows:

1. Master Data Console Schedule.
2. Vehicle-Station Summary
3. Vehicle-Acquisition Schedule.
4. Vehicle-Switch Schedule.
5. Station-Acquisition Schedule.
6. Bird Buffer Schedule.
7. 1604 Allocation Conflict List.
8. 1604 Short Term Schedule.
9. 1604 Daily Usage Plan.
10. Conflict Resolution Work Plan.
11. Simulated Launch Schedule.
12. RFI Conflict List.

6.8 SIMULATION AND DATA REDUCTION MODULE

This module facilitates program checkout and permits study of special situations better specified by non-standard inputs. It can furnish non-standard outputs, such as the contents of internal tables, for purposes of checkout and research and development data. It can generate distributions, compute means and standard deviations, establish correlations, and perform analysis of variance. Its purpose is to complement analysis of data obtained by simulation and data obtained from external sources.

6.9 CONTROL MODULE

This module maintains control over the other SCHOPS modules and directs the sequence of operation of these modules.

REFERENCES

1. "Implementation Plan Augmentation Computer Programs", System Development Corporation, TM-751/000/00, September 4, 1962.
2. "Augmentation of the USAF Satellite Control Facility" (U), Aerospace Corporation, TOR-930 (2110)-1, April, 1962. (SECRET)
3. "Satellite Control Facilities Capabilities Manual" (U), 6594th Aerospace Test Wing, AFSC, Sunnyvale California. TWRDE-61-26, (CONFIDENTIAL)
4. "Bird Buffer Combined Milestone 3-4," System Development Corporation, TM-834/000/OA, February 11, 1963.
5. "Command System", Aerospace Corporation, AS-62-0000-07768. (SECRET)
6. "New and Modified 1604 Computer Programs in Support of Augmentation-- Milestone 3", System Development Corporation, TM-840, November 20, 1962.
7. "Data Handling Subsystem Specification", Philco Corporation, WDL-98-2046B-09, November 5, 1962.
8. "Control and Display Subsystem Specification", Philco Corporation, WDL-98-2048A-09, August 10, 1962.
9. "Data Subsystem Diagnostic and Maintenance Computer Programs Multiple Satellite Augmentation Program", Philco Corporation WDL- TR1950, November 26, 1962.
10. "Scheduling Operations (SCHOPS) Milestone 4", System Development Corporation, TM-(L)-795/000/02, February 7, 1963.
11. "Augmented SCF Tracking Station Equipment Configurations Description" (U), System Development Corporation, TM(L)-880/000/01, March 1, 1963 (SECRET).
12. "Milestone 3 for Control 160A Computer at STA", Lockheed Aircraft Corporation, LMSC-656884, November 9, 1962.
13. "Master Data Control Console Design Specification", Lockheed Aircraft Corporation, LSMD Spec. 1415194, September 6, 1962.
14. "Communication Data Select and Cross Connect Unit", Lockheed Aircraft Corporation, LMSC Spec 1415185, September 5, 1962.
15. "Computer Select and Cross Connect Unit", Lockheed Aircraft Corporation, LMSC Spec 1415190, September 5, 1962.

1 April 1963

93
(last page)

TM-1146/000/00

16. "FM/FM Telemetry Ground Station Subsystem Specification", Philco Corporation, WDL-98-2045C-09, August 16, 1962.
17. "Telemetry Data Flow for the Augmented SCF", System Development Corporation, TM(L)-949/000/00, January 14, 1963
18. "Multiple Satellite Augmentation Program Tracking Station Computer Operational Programs (Milestone 2 & 3)", Philco Corporation WDL-TR1931, November 15, 1962.
19. "Characteristics of the Model 1604 Computer", Control Data Corporation, Publication No. 018c, May 1, 1961.
20. "Milestone 4 - MSAP Tracking Station Operational Computer Program Design Specification", Philco Corporation, WDL-TR1957, February 4, 1963.

1 April 1963

TM-1146/000/00

EXTERNAL DISTRIBUTION LIST

Space Systems Division
(Contracting Agency)

Maj. C. R. Bond (SSOCD)
Maj. N. D. LaVally (SAFSP-206)

6594th Aerospace Test Wing
(Contracting Agency)

Col. A. W. Dill (TWRD) (10)
Lt. Col. M. S. McDowell (TWRU) (20)
TWACS

PIR-E1 (Lockheed)

J. A. Boysen
N. N. Epstein
W. E. Moorman
G. F. Vader
P. E. Williams
G. F. Taylor

PIR-E2 (Philco)

J. A. Bean
J. A. Isaacs
R. Morrison
S. M. Stanley

PIR-E3 (LFE)

D. F. Criley
K. B. Williams

PIR-E4 (GE-Santa Clara)

D. Alexander

PIR-E4 (GE-Sunnyvale)

J. Farrentine
N. Kirby

PIR-E4 (GE-Box 8555)

J. S. Brainard
R. J. Katucki
J. D. Selby

PIR-E4 (GE-3198 Chestnut)

J. F. Butler
C. A. Cummings
H. D. Gilman

PIR-E4 (GE-Bethesda)

W. L. Massey

PIR-E4 (GE-Box 8661)

F. T. Clark
J. D. Roger
W. R. Weinrich

PIR-E5 (Aerospace)

F. M. Adair
A. Bakst
J. W. Bengston
F. V. Bigelow
F. O. Brandsberg
L. H. Garcia
G. J. Hansen (3)
L. J. Kreisberg
M. L. Luther
T. R. Parkin
E. E. Retzlaff
H. M. Reynolds
D. Saadeh
R. G. Stephenson
D. D. Stevenson
V. White

PIR-E7 (STL)

A. J. Carlson (3)

PIR-E8 (Mellonics)

F. Druding

1 April 1963

TM-1146/000/00

WINSOR, M. E.
WINTER, J. E.
WISE, R. C.

22156
24117
22085

WONG, J. P.
ZUBRIS, C. J.

SUNNYVALE
24075

UNCLASSIFIED

System Development Corporation,
Santa Monica, California
AUGMENTED SATELLITE CONTROL FACILITY
SYSTEM DESCRIPTION.
Scientific rept., TM-1146, by S. Weems.
1 April 1963, 93p., 20 refs. 11 figs.
(Contract AF 19(628)-1648, Space Systems
Division Program, for Space Systems
Division, AFSC)

Unclassified report

DESCRIPTORS: Satellite Networks.
Programming (Computers).

UNCLASSIFIED

Describes the Augmented Satellite
Control Facility (SCF) from two points
of view: first, the equipment subsystems
are described in terms of their
capabilities, functions and primary
usages; second, the principal activities
performed by the SCF; i.e., telemetry,
tracking, commanding, and scheduling are
explained in such a way that the
previously described equipments are tied
together into systems, with emphasis on
the functional aspects of SCF operations.

UNCLASSIFIED

UNCLASSIFIED

UNCLASSIFIED

UNCLASSIFIED